



# INFO CENTRE ADR

## OPERATOR'S GUIDE



ISSUE 1 - 01/01/ 1999 - 000 700 091

GB

# INFO CENTRE ADR

## INTRODUCTION

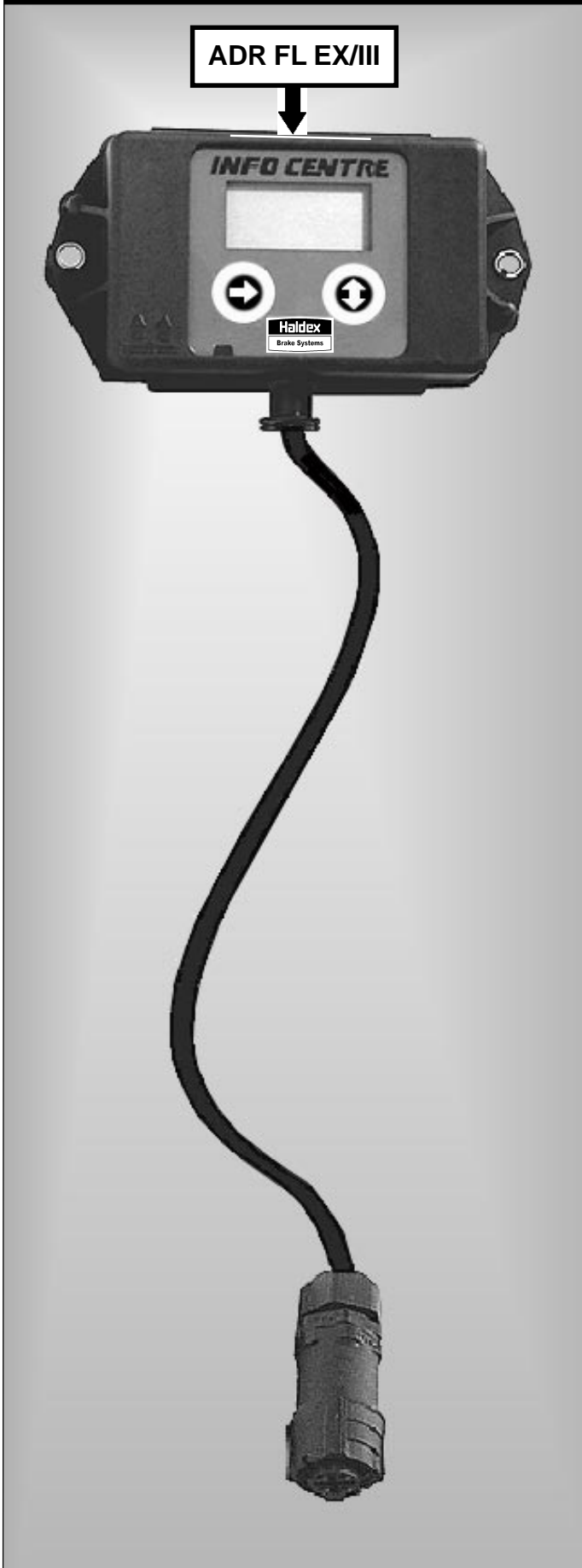

Info Centre ADR has been specifically designed to comply to ADR regulations FL and EX/III and is suitable for use on vehicles carrying flammable liquids, gases or explosive materials.



To ensure that the correct version of Info Centre has been or is about to be installed, please inspect the label which is located on the top of the Info Centre enclosure as shown on the diagram on the left. The text on the label should read: **ADR FL EX/III** indicating that the Info Centre complies to those regulations.

Under no circumstances should an Info Centre without the ADR label be fitted to a vehicle carrying either flammable liquids, gases or explosive materials.

INFO CENTRE ADR is a side of trailer mounted diagnostic unit used for readout of odometer and fault codes, plus other information as available in the ABS Electronic Control Unit (ECU).

The INFO CENTRE ADR is normally connected permanently to the ECU's diagnostic connection **and can only be used whilst vehicle powered.**

**While the ECU is powered from its normal sources (stoplight or permanent)** information is transferred to the Info Centre's memory, which can be recalled. Power is supplied from the vehicle system via the ECU diagnostics connector.

INFO CENTRE ADR comprises an LCD (Liquid Crystal Display) and two buttons marked up/down and right arrows. The up/down button accesses the next main menu item, the left button, marked right arrow, is used for sub menu items.

For adjustment of settings a watch style procedure is followed; the up/down button is held down for 2 seconds, then the first digit flashes and can then be increased by pressing the up/down button. The next digit is then selected using the right arrow button and so on.

INFO CENTRE ADR is housed in a plastic enclosure provided with a cover boot for environmental protection.

# INFO CENTRE ADR

**Principal Functions:**
**Odometer:**

Total distance  
 Trip distance  
 Service interval  
 Distance to next Service  
 Tyre scale setting

**Diagnostic:**

Display Current fault code  
 Display Stored fault codes  
 Sensor / cabling check

**Testing:**

Reset-to-Ride (COLAS)  
 Tacho  
 Retarder







**ECU Information:**

Serial number  
 Product type code  
 Configuration code  
 Auxiliary code  
 Re-Configure ABS ECU (adding or removing COLAS)

**Pin:**

Security number

**MEANING OF LCD**

	<b>BATTERY:</b> - OFF = OK - ON = Internal ABS ECU battery failure. Diagnostic functions and ECU information available only
	<b>LOCK:</b> Incorrect ABS ECU connected to Info Centre. Odometer functions not available.
	<b>POWER:</b> Vehicle power - ON = Vehicle supply - OFF = No vehicle supply - FLASHING = Communications established between Info Centre and ABS ECU.
	<b>ODOMETER DISPLAY</b> - Total distance - Trip distance
	<b>ADJUSTMENT ARROWS: Editing mode</b> - ON = Indicates that information may be changed by user.
	<b>SERVICE FUNCTION / SERVICE DUE</b> <b>Indicates service is due:</b> - ON = Whilst displaying the odometer value indicates service is due, - FLASHING = Current ABS fault

# INFO CENTRE ADR

### FUNCTIONS : VEHICLE POWER ON

ALL SEGMENT CONFIG-  
DISPLAY TEST URATION CODE DIAGNOSTIC CODE

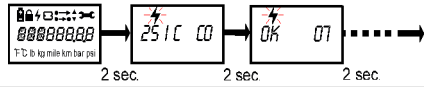

### ODOMETER MODE

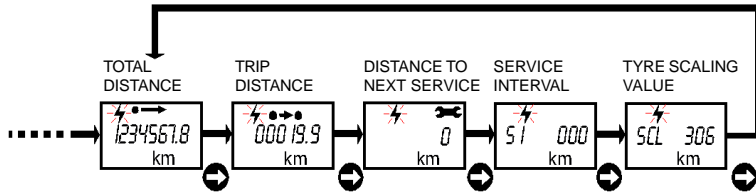

### RESET TRIP DISTANCE

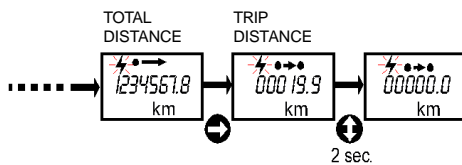

### DIAGNOSTIC INFORMATION

DISPLAY 'OK' IF NO CURRENT FAULTS

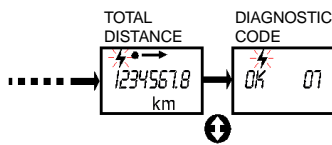

STORED DIAGNOSTIC CODE

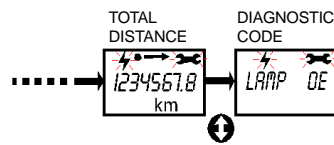

### ECU INFORMATION (ABS ONLY)

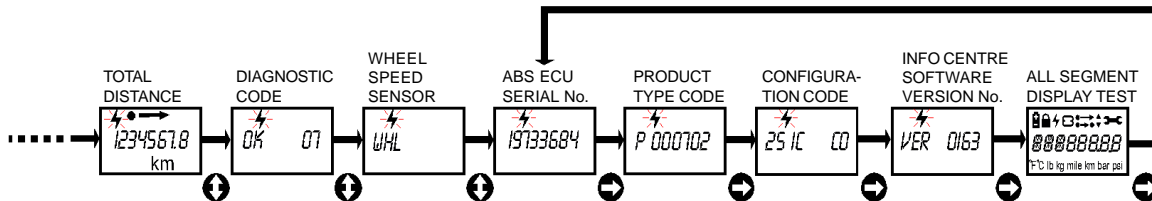

### ECU INFORMATION (ABS + COLAS)

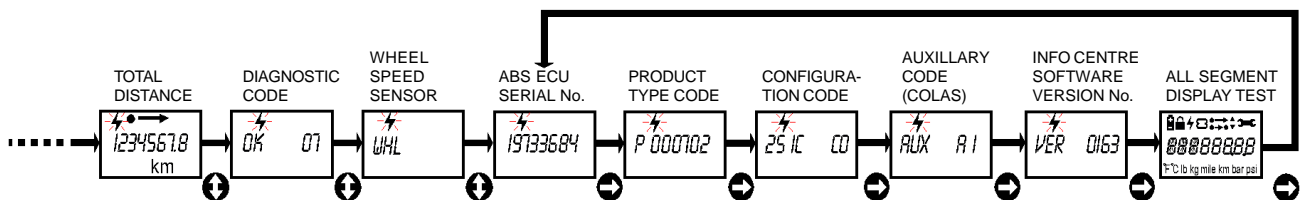

### SECURITY NUMBER

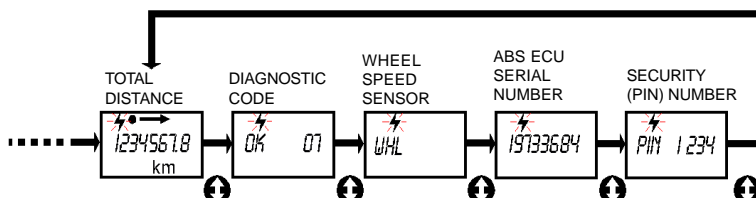

# INFO CENTRE ADR

### FUNCTIONS : VEHICLE POWER ON

ALL SEGMENT CONFIG-  
DISPLAY TEST URATION CODE DIAGNOSTIC CODE

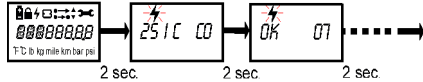

### DIAGNOSTIC INFORMATION

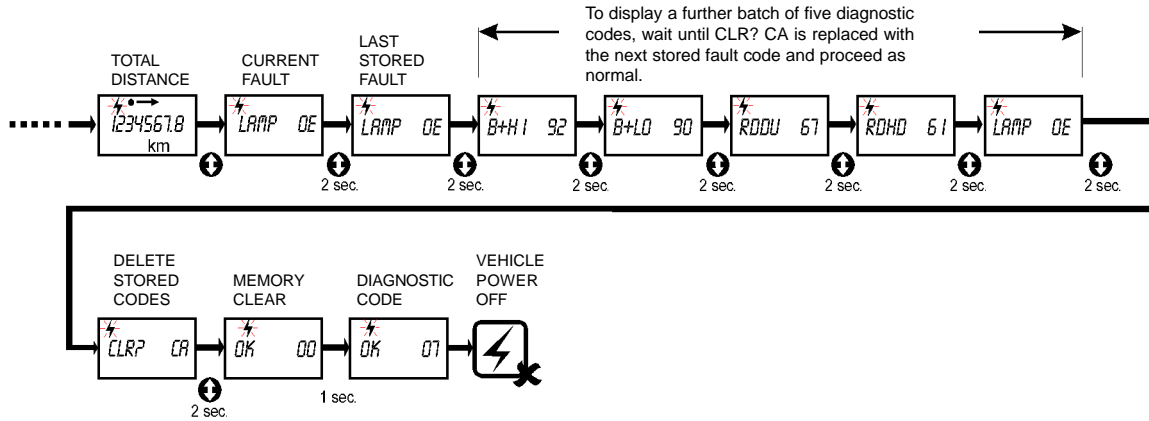

### SENSOR OUTPUT / CABLING CHECK

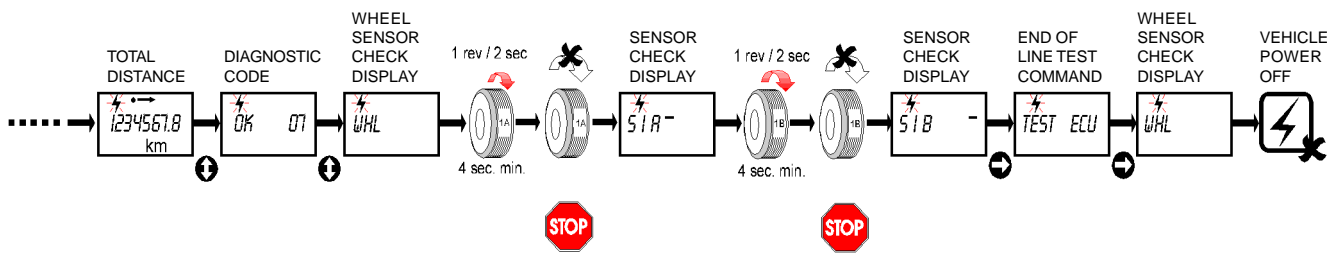

### SET SERVICE INTERVAL AND SET DISTANCE TO NEXT SERVICE

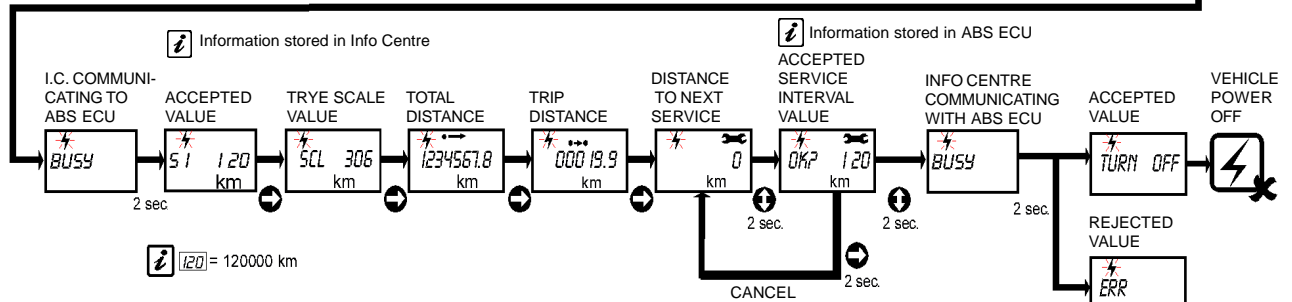
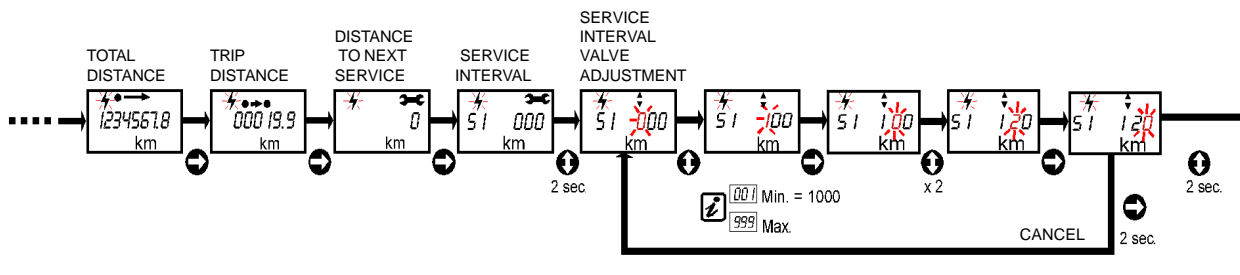

**Possible Causes:**  
No vehicle power, cable damaged connections, tyre scaling factor out of range (100-999)

### CANCEL DISTANCE TO NEXT SERVICE

Set service interval to zero

# INFO CENTRE ADR

### FUNCTIONS : VEHICLE POWER ON

#### RECONFIGURE ABS ECU - COLAS ADDED OR REMOVED

##### (PART 1) COLAS NOT CONNECTED

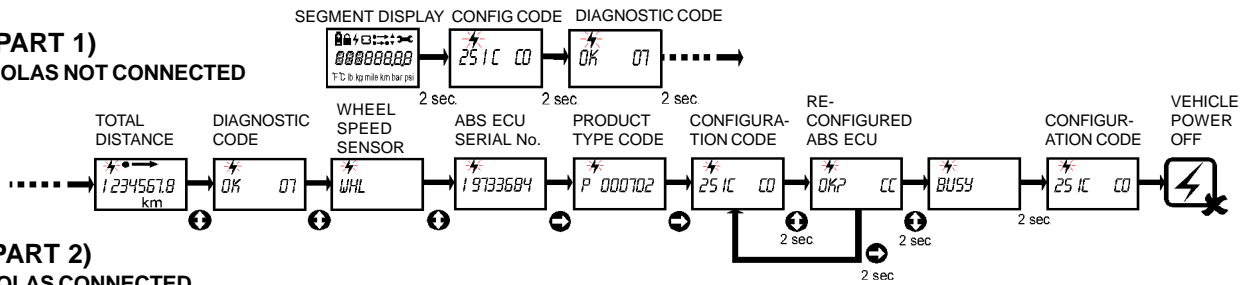

##### (PART 2) COLAS CONNECTED

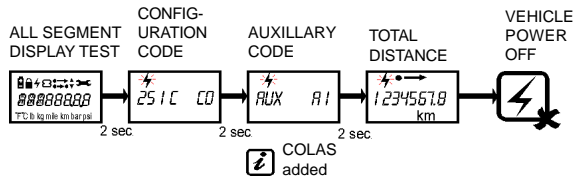

#### TEST MODE

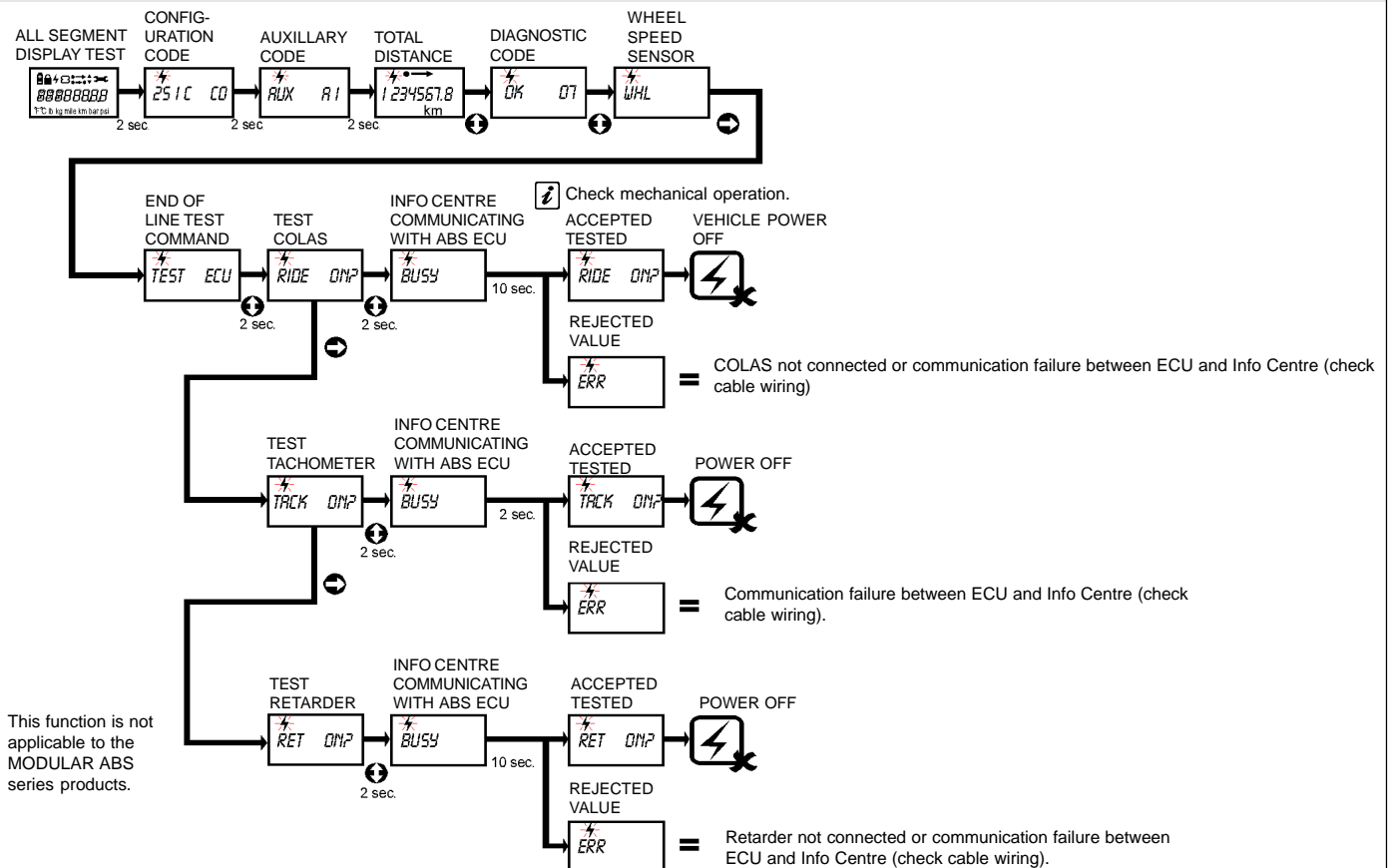

#### INFO CENTRE OR ABS ECU REPLACED - LOCK SYMBOL

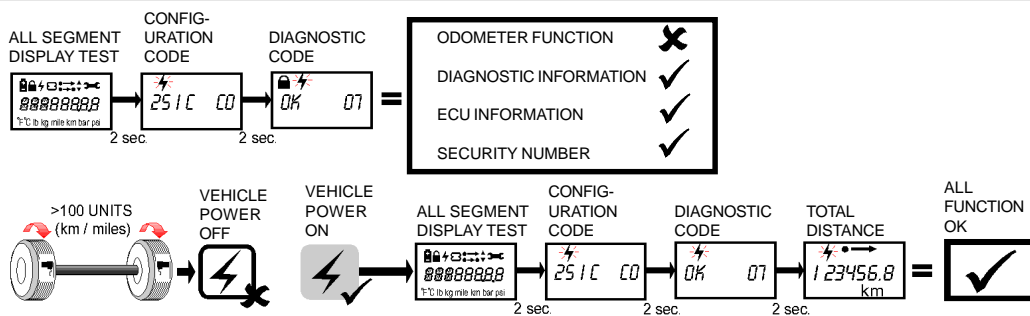

# INFO CENTRE ADR

### FUNCTIONS : VEHICLE POWER ON

#### SET TYRE SCALING

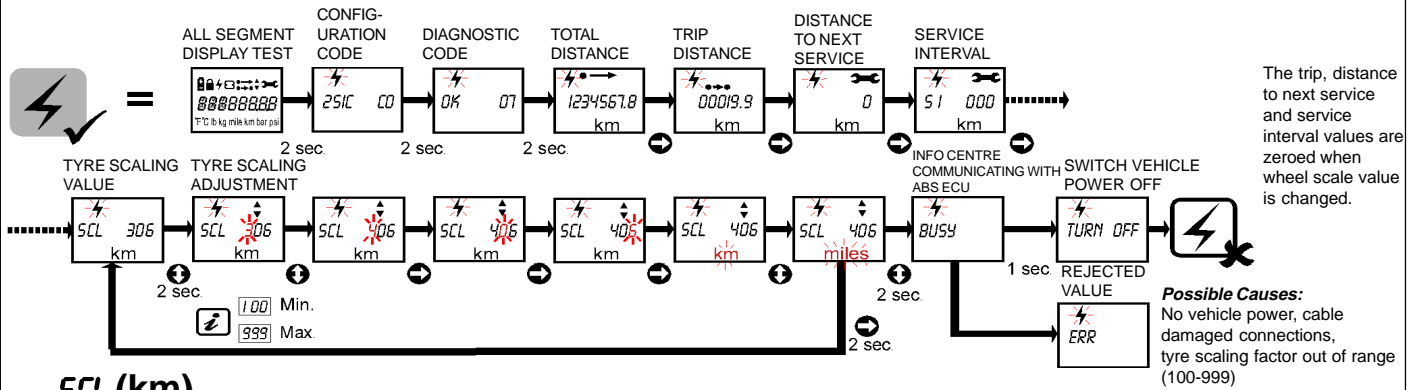

#### SCL (km)

	SCL (km)	SCL (km)		SCL (km)	SCL (km)		SCL (km)	SCL (km)
C 22.5 PILOTE X	265	332	11.00 R 22	288		275/80 R 18	296	
D 20 PILOTE X	260	325	11/70 R 22.5	274	342	275/80 R 20	277	346
D 20 TYP X	249	311	12 R 22.5		303	275/80 R 22.5	259	324
D 22.5 PILOTE X	259	324	12.00 R 20	292		285/60 R 22.5	282	353
E 20 PILOTE X	250	313	12.00 R 22	281		285/70 R 19.5	293	
E 20 TYP		303	12.00 R 24	267		295/60 R 22.5	282	352
E 22 TYP X		288	12.0 - 18	302		295/70 R 22.5	266	333
E 22.5 PILOTE X	250	313	12.5 R 20	256	320	295/80 R 22.5	251	314
F 20 PILOTE X	302		12/80 R 20	260	325	305/60 R 22.5	278	347
F 20 TYP X	291		12/80 R 22.5	250	313	305/70 R 19.5	284	355
G 20 TYP X	266		13 R 20 PILOTE		289	305/70 R 22.5	263	328
6.00 R 16	357		13 R 22.5		291	305/70 R 23.5		285
6.00 R 18	333		13.0/55 - 16	326		315/60 R 22.5	276	344
6.5 R 16	352		13.0/65 R 18	299		315/70 R 22.5	259	323
6.5 R 20	302		13.00 R 20	279		315/75 R 17.5	338	
6.50 R 17	340		13/75 R 22.5	250	313	315/75 R 22.5	252	315
7 R 17.5	349		13/80 R 20	250	313	315/80 R 22.5	244	305
7 R 19.5	328		14.00 R 20	265		325/65 R 16	328	
7.00 R 16	338		14.5 R 20		301	325/65 R 18	299	
7.00 R 20	293		14.5-20 MPT	249	311	335/65 R 18	300	
7.50 R 15	340		14.75/80 R 20	289		335/80 R 18	271	339
7.50 R 16	324		14/80 R 20	301		335/80 R 20	251	314
7.50 R 20	283	354	15 R 22.5	246	307	355/60 R 18	299	
8 R 17.5	334		15.0/55 R 18	302		365/70 R 22.5		303
8 R 19.5	306		16.00 R 20	247		365/80 R 20		300
8 R 22.5	280	351	16.5 R 19.5	252	315	365/80 R 22.5		297
8.25 R 15	314		16.5 R 22.5	294		375/75 R 20	245	307
8.25 R 16	305		16/70-20 MPT	253	316	385/55 R 18	302	
8.25 R 17	297		18 R 19.5	244	305	385/55 R 19.5	287	359
8.25 R 20	273	341	18 R 22.5		285	385/65 R 19.5	263	329
8.5 R 17.5	327		205/75 R 17.5	348		385/65 R 22.5	245	306
9 R 17.5	320		215/75 R 16	357		405/70 R 20	244	305
9 R 19.5	293		215/75 R 17.5	342		425/55 R 19.5	269	336
9 R 22.5	270	338	225/65 R 15	349		425/65 R 22.5		291
9.00 R 16	286	358	225/75 R 16	350		425/75 R 20		292
9.00 R 20	258	322	225/75 R 17.5	335		445/45 R 19.5	288	360
9.5 R 17.5	311		235/75 R 17.5	329		445/65 R 19.5	244	305
10 R 17.5	306		245/70 R 17.5	330		445/65 R 22.5		285
10 R 22.5	257	322	245/70 R 19.5	313		500/55-20	264	330
10.0 R 15	285	357	255/70 R 22.5	282	353	525/65 R 20.5		274
10.00 R 20	249	311	265/70 R 17.5	302		545/45-17	276	344
10.5 R 20	277	346	265/70 R 19.5	302		550/60-22.5		275
10.5 R 20 MPT	279	349	275/65 R 16	348		550/65-22.5		276
11 R 22.5	250	312	275/65 R 18	324		555/45-17	274	343
11.00 R 20	303		275/70 R 22.5	271	339			

1 km = 0.6214 miles  
1 mile = 1.6093 km

$$SCL = (1000 / Rc) \times (T / 100)$$

Rc = Rolling circumference in metres  
T = Exciter actual tooth count

# INFO CENTRE ADR

## DIAGNOSTIC CODES :

<div style="border: 1px solid black; width: 40px; height: 20px; margin: 0 auto;"></div>	NO DISPLAY - No supply on ignition switch line. <b>Possible causes:</b> Fuse blown. INFO CENTRE or cable fault. Open circuit B -
<div style="display: flex; justify-content: space-around; align-items: center;"> <div style="border: 1px solid black; padding: 2px;">S 1A -</div> <div style="font-size: 2em; margin: 0 10px;">/</div> <div style="border: 1px solid black; padding: 2px;">S 1B -</div> </div>	BAR DISPLAYED = Sensor output O.K. ( Example: 1A, 1B Sensor) BAR NOT DISPLAYED = Sensor output too low
<div style="border: 1px solid black; padding: 2px;">OK 00</div>	System is O.K. vehicle is moving above 10km/hr
<div style="border: 1px solid black; padding: 2px;">S1A 01</div>	1A Sensor/wiring open or short circuit
<div style="border: 1px solid black; padding: 2px;">S1B 02</div>	1B Sensor/wiring open or short circuit
<div style="border: 1px solid black; padding: 2px;">S2A 03</div>	2A Sensor/wiring open or short circuit
<div style="border: 1px solid black; padding: 2px;">S2B 04</div>	2B Sensor/wiring open or short circuit
<div style="border: 1px solid black; padding: 2px;">S3A 05</div>	3A Sensor/wiring open or short circuit
<div style="border: 1px solid black; padding: 2px;">S3B 06</div>	3B Sensor/wiring open or short circuit
<div style="border: 1px solid black; padding: 2px;">OK 07</div>	System is O.K. vehicle is stationary
<div style="border: 1px solid black; padding: 2px;">RET 08</div>	Retarder relay / Wiring open circuit
<div style="border: 1px solid black; padding: 2px;">RET 09</div>	Retarder relay / Wiring short circuit
<div style="border: 1px solid black; padding: 2px;">RIDE 0C</div>	COLAS solenoid / Wiring short circuit
<div style="border: 1px solid black; padding: 2px;">RIDE 0A</div>	COLAS solenoid / Wiring open circuit
<div style="border: 1px solid black; padding: 2px;">LAMP 0E</div>	Warning lamp circuit fault
	<b>LOW SENSOR OUTPUT GROUP</b>
<div style="border: 1px solid black; padding: 2px;">S1A 11</div>	1A Sensor system fault
<div style="border: 1px solid black; padding: 2px;">S1B 12</div>	1B Sensor system fault
<div style="border: 1px solid black; padding: 2px;">S2A 13</div>	2A Sensor system fault
<div style="border: 1px solid black; padding: 2px;">S2B 14</div>	2B Sensor system fault
<div style="border: 1px solid black; padding: 2px;">S3A 15</div>	3A Sensor system fault
<div style="border: 1px solid black; padding: 2px;">S3B 16</div>	3B Sensor system fault
	<b>Possible causes:</b> Sensor worn, maladjusted sensor, wiring open or short circuit.
<div style="border: 1px solid black; padding: 2px;">EXC 20</div>	Incorrect exciter type.



# INFO CENTRE ADR

## DIAGNOSTIC CODES :

DIAGNOSTIC CODES :	
	<b>INTERMITTENT LOW SENSOR OUTPUT GROUP</b>
S1A 21	1A Sensor system fault
S1B 2	1B Sensor system fault
<sup>2</sup> S2A 23	2A Sensor system fault
S2B 2	2B Sensor system fault
<sup>4</sup> S3A 2	3A Sensor system fault
<sup>5</sup> S3B 26	3B Sensor system fault
cable insulation.	<b>Possible causes:</b> Loose sensor, connection bracket or exciter. Dented exciter. Maladjusted sensor or worn sensor
EXT 37	Lamp signalled by external device.
	<b>ONE WHEEL WITH SLOW RECOVERY GROUP</b>
XSEM 40	Sensor wiring crossed across an axle
SLW 41	Slow recovery of one wheel of red channel
SLW 4	Slow recovery of one wheel of blue channel
<sup>2</sup> SLW 43	Slow recovery of one wheel of yellow channel
fault	<b>Possible causes:</b> Slow brake release, foundation brake mechanical faults, dry bearings, broken spring, restricted piping. Modulator check for kinks and blockages etc. Incorrect piping, wiring.
	<b>OPEN CIRCUIT MODULATOR SOLENOID OR SOLE-WIRING GROUP</b>
<sup>NOID</sup> RDHd 61	Hold solenoid circuit fault, red channel
BUHd 62	Hold solenoid circuit fault, blue channel
YEHd 63	Hold solenoid circuit fault, yellow channel
RDDu 67	Dump solenoid circuit fault, red channel
BUDu 68	Dump solenoid circuit fault, blue channel
YEDu 69	Dump solenoid circuit fault, yellow channel

# INFO CENTRE ADR

## DIAGNOSTIC CODES :

<b>DIAGNOSTIC CODES :</b>	
	<b>SHORT CIRCUIT ACROSS MODULATOR SOLENOID OR SOLENOID WIRING GROUP</b>
<i>RDHd 71</i>	Hold solenoid circuit fault, red channel
<i>BUHd 72</i>	Hold solenoid circuit fault, blue channel
<i>YEHd 73</i>	Hold solenoid circuit fault, yellow channel
<i>RDDu 77</i>	Dump solenoid circuit fault, red channel
<i>BUDu 78</i>	Dump solenoid circuit fault, blue channel
<i>YEDu 79</i>	Dump solenoid circuit fault, yellow channel
	<b>MODULATOR SOLENOID WIRING OR SOLENOID SHORT TO B+ GROUP</b>
<i>SOL 80</i>	Poor insulation in the modulator solenoid or wiring fault.
<i>RDHd 81</i>	Hold solenoid circuit fault, red channel.
<i>BUHd 82</i>	Hold solenoid circuit fault, blue channel.
<i>YEHd 83</i>	Hold solenoid circuit fault, yellow channel.
<i>RDDu 87</i>	Dump solenoid circuit fault, red channel.
<i>BUDu 88</i>	Dump solenoid circuit fault, blue channel.
<i>YEDu 89</i>	Dump solenoid circuit fault, yellow channel.
	<b>SUPPLY VOLTAGE GROUP</b>
<i>B+LO 90</i>	Supply voltage at ECU less than 18v when a solenoid is energised.
<i>ISOI 91</i>	Faulty supply from ISO 7638 Pin 1 or fuse blown.
<i>B+HI 92</i>	Supply voltage at the ECU greater than 32v.
<i>ECU 93</i>	Internal ABS ECU fault.
<i>ECU 99</i>	Internal ABS ECU fault.
	<b>SYSTEM FUNCTION GROUP</b>
<i>AUX A1</i>	Reset to ride height
<i>AUX A2</i>	Retarder

# INFO CENTRE ADR

<b>DIAGNOSTIC CODES :</b>	
	<b>MISCELLANEOUS CODES</b>
<b>CLR CA</b>	Erase stored fault.
<b>CLR CC</b>	Clear Configuration.
<b>CF</b>	Sensors and Solenoid not connected.
<b>COM FAIL</b>	Communication failure between ABS ECU and INFO CENTRE, open or short circuit wiring.
	<b>PRODUCT TYPE GROUP</b>
<b>P 000501</b>	<b>MODULAR 2 24v</b> (ABS ECU = 364 279 201)
<b>P 000502</b>	<b>MODULAR 2 24v ADR</b> (ABS ECU = 364 279 202)
<b>P 000701</b>	<b>MODULAR 1 Upgrade 24v</b> (ABS ECU = 364 279 002)
<b>P 000702</b>	<b>MODULAR 1 Plus 24v</b> (ABS ECU = 364 279 101)
	<b>CONFIGURATION CODES</b>
<b>2S 1C C0</b>	2S/1M
<b>2S 2C C1</b>	2S/2M
<b>4S 2C C2</b>	4S/2M
<b>4S 2C C3</b>	4S/2M - Axle 2 or 3 lifted

**For further information:**

**Austria**  
Haldex Wien Ges.m.b.H  
Vienna  
Tel: + 43 1865 16 40  
Fax: + 43 1865 16 4027  
e-mail: office@baeder-haldex.at

**Belgium**  
Haldex N.V./S.A.  
Zaventem (Brussels)  
Tel: + 32 2725 3707  
Fax: + 32 2752 4099  
e-mail: info@hbe.haldex.com

**Brazil**  
Haldex do Brazil  
São Paulo  
Tel: + 55 11 531 4999  
Fax: + 55 11 531 9515  
e-mail: info@hbr.haldex.com

**China**  
Haldex International Trading Co. Ltd.  
Shanghai  
Tel: + 86 21 6289 4469  
Fax: + 86 21 6279 0554  
e-mail: haldex@public.sta.et.cn

**France**  
Haldex Europe S.A.  
Weyersheim (Strasbourg)  
Tel: + 333 88 68 22 00  
Fax: + 333 88 68 22 09  
e-mail: info@hfr.haldex.com

**Germany**  
Haldex Brake Products G.m.b.H  
Denkendorf (Stuttgart)  
Tel: + 49 711 93 49 17 0  
Fax: + 49 711 93 49 17 40  
e-mail: info@hde.haldex.com

**Haldex Brake Products G.m.b.H**  
Heidelberg  
Tel: + 49 6221 70 30  
Fax: + 49 6221 70 34 00  
e-mail: info@hbpde.haldex.com

**Great Britain**  
Haldex Ltd.  
Newton Aycliffe  
Tel: + 44 1 325 310 110  
Fax: + 44 1 325 311 834  
e-mail: info@huk.haldex.com

**Haldex Brake Products Ltd.**  
Redditch  
Tel: + 44 1527 499 499  
Fax: + 44 1527 499 500  
e-mail: info@hbpuk.haldex.com

**Poland**  
Haldex Sp z o.o.  
Praszka  
Tel: + 48 34 350 11 00  
Fax: + 48 34 350 11 11  
e-mail: info@haldex.net.pl

**South Korea**  
Haldex Korea Ltd.  
Seoul  
Tel: + 82 2 2636 7545  
Fax: + 82 2 2636 7548  
e-mail: haldexk@mail.hkr.haldex.com

**Spain**  
Haldex España S.A.  
Parets del Valles (Barcelona)  
Tel: + 34 93 573 1030  
Fax: + 34 93 573 0728  
e-mail: haldexsa\_esp@passwordsta.es

**Sweden**  
Haldex Brake Products AB  
Landskrona  
Tel: + 46 418 47 6000  
Fax: + 46 418 47 6001  
e-mail: info@hbpse.haldex.com

**USA**  
Haldex Brake Products Corp.  
Kansas City  
Tel: + 1 816 891 2470  
Fax: + 1 816 891 9447  
e-mail: info@hbpus.haldex.com

## Company Vision

We use our demonstrated competence to provide innovative components, systems and service for trucks, trailers and buses, that lower life cycle costs and improve vehicle safety. Haldex wants to become the first choice business partner of commercial vehicle manufacturers world wide in the areas of braking and suspension control systems with special emphasis on heavy commercial vehicles.

## Total Support

A uniquely wide range of services is available from Haldex. These include expert consultancy for braking and suspension development, brake calculations, type approvals and application engineering. The aim is accurate specification for manufacturers and low cost of ownership for the operator. Full aftermarket support includes a Worldwide parts distribution and service network, on-line technical advice, field visits and installation/maintenance training held on-site or at Haldex facilities.

## Research and Development

Continual, heavy investment in Research and Development is carried out in response to ever increasing commercial, legislative, environmental, performance and technological demands.

## Quality and Production Standards

The very latest production technology ensures the very highest quality standards. All production sites are ISO 9001 approved.



The Haldex Group is a global supplier of proprietary products for trucks, cars and industrial vehicles, with special emphasis on performance and safety. The Group is organized in Divisions which focus on their respective product niche:

**Haldex Brake Systems** supplies ABS and brake components for heavy vehicle air brakes.

**Haldex Barnes Hydraulics** supplies gear pumps and hydraulic systems for power steering and lifting functions on industrial vehicles and trucks.

**Haldex Garphyttan Wire** supplies specially steel-alloyed wire products mainly for applications in combustion engines.

**Haldex Traction Systems** supplies 4WD systems for cars and trucks.

Sales companies are established in Europe, North and South America and Asia. Production takes place in 9 factories in USA, 9 factories in Europe and 1 joint venture in India.

The Haldex Group is listed on the Stockholm Stock Exchange.



**Innovative Vehicle Technology**