

PART No.
364 588 000 2

COMPUTER PRODUCED DRAWING
MUST NOT BE CHANGED MANUALLY

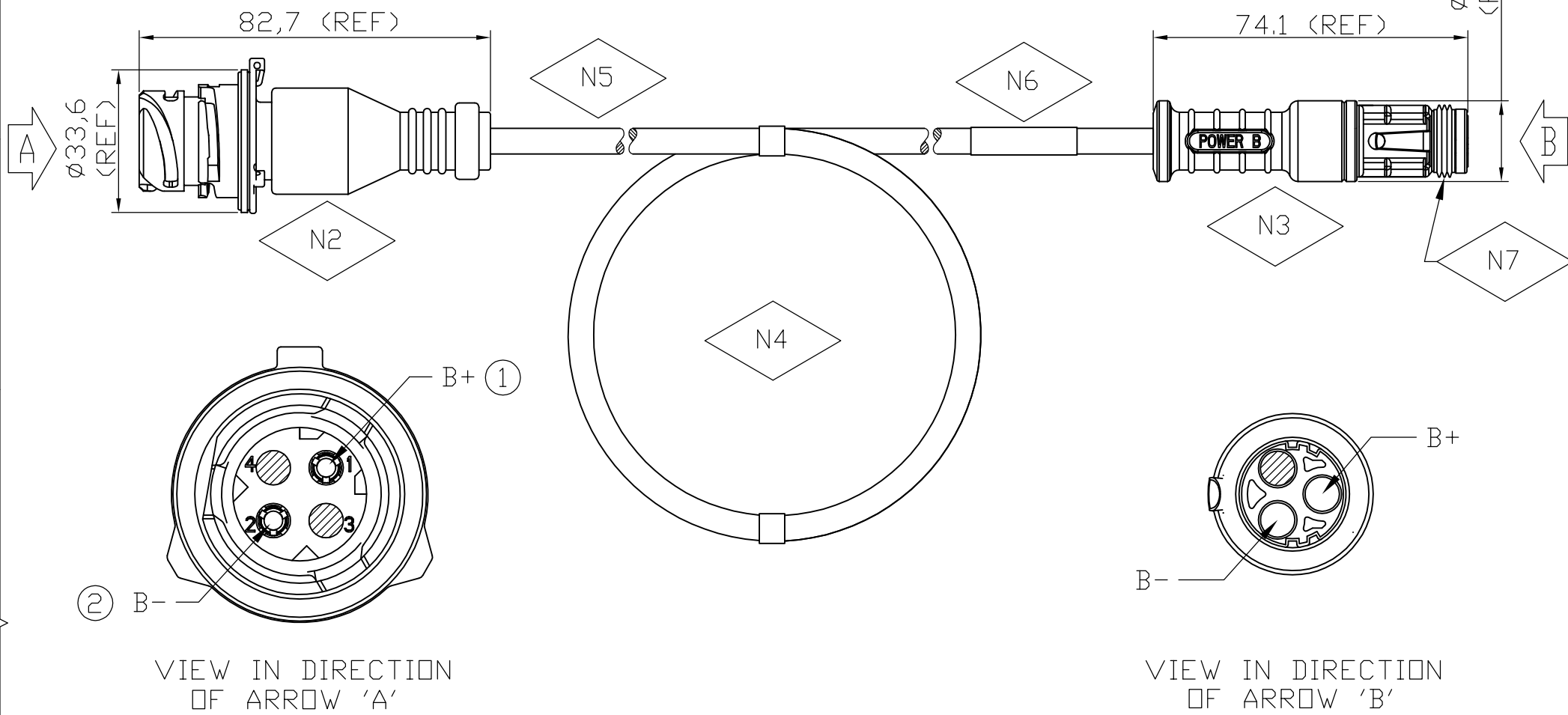

- N 1 SEE CHART FOR CABLE ASSEMBLY PART NUMBER.
- N 2 CONFORMS TO IP67 (BS EN 60529) WHEN MATED WITH SOCKET DIN 72585 (ISO 15170) STYLE CONNECTORS.
- N 3 CONFORMS TO IP67 (BS EN 60529) WHEN MATED WITH UABS ECU.
- N 4 CABLE IS SUPPLIED COILED IN A PLASTIC BAG.
- N 5 CABLE INSULATION MATERIAL - PVC CABLE MAX. DIAMETER - 6.9mm WIRE CORE CSA - 1.5mm².
- N 6 PART NUMBER IDENTIFICATION.
- N 7 SEAL TO BE PROTECTED FROM DAMAGE PRIOR TO ASSEMBLY.

VIEW IN DIRECTION OF ARROW 'A'

VIEW IN DIRECTION OF ARROW 'B'

ASSY. No.	LENGTH
364 588 001	2m
364 588 011	4m

K **T** **M** THIS DRAWING/SPECIFICATION USES CLASSIFIED CHARACTERISTIC SYMBOLS DEFINED IN QUALITY PROCEDURE 4.17

ISS	CHANGE	CHEC	DATE	ISS	CHANGE	CHEC	DATE
4	C6101_2	MPH	02-07-15				
3	C6420	MPH	04-02-13				
2	C6324	MPH	19-09-12				
1	PR2080_5	MPH	11-06-12				

AutoCAD PART
THIS DRAWING/DOCUMENT IS COPYRIGHT AND THE PROPERTY OF HALDEX BRAKE PRODUCTS LIMITED. IT MUST NOT BE COPIED (IN WHOLE OR IN PART) USED FOR MANUFACTURE OR OTHERWISE DISCLOSED WITHOUT PRIOR WRITTEN CONSENT OF THE COMPANY. ANY COPIES OF THIS DRAWING/DOCUMENT MADE BY ANY METHOD MUST ALSO INCLUDE A COPY OF THIS LEGEND. © 2012

NOTE: UNLESS OTHERWISE STATED THE FOLLOWING APPLIES
1 ISO METHOD A \oplus PROJECTION.
2 S.I. UNITS.
3 SURFACE FINISH TO BS 308/BS 1134.
4 DIMS. APPLY AFTER CHEMICAL OR ELECTRO-PLATED FINISH.
5 WELD SYMBOLS TO BS 499.
6 D DATUM DIMENSIONS.
7 METRIC THREADS TO BS 3643/DIN 13.
8 UNIFIED THREADS TO BS 1580.

ASSOC SPECS.	BS EN 60529				
MATERIAL		DRAWN	M. HOLDER	DATE	11-06-12
HEAT TREATMENT		CHECKED	<i>Calpe</i>	DATE	07/07/15
FINISH		APPROVED SPECIALIST	<i>M. Holder</i>	DATE	02/07/15
FORM		APPROVED FOR ISSUE	<i>WJ</i>	DATE	10/08/15

TITLE
24N TO DIN
72585 - UABS
SCALE NTS
WAS -
SHEET 1 OF 1

HALDEX BRAKE PRODUCTS LTD
MIRA TECHNOLOGY PARK
LINDLEY WARKS
CV13 6DE
PART No.
364 588 000 2
A3

