

(C) THIS DOCUMENT IS THE PROPERTY OF THE HALDEX GROUP, AND CONTAINS CONFIDENTIAL AND PROPRIETARY INFORMATION THAT CANNOT BE REPRODUCED, UTILIZED OR DIVULGED, IN WHOLE OR IN PART, WITHOUT WRITTEN AUTHORIZATION					
REV	CHANGE DESCRIPTION AND ORDER NUMBER	DATE	CHANGED	CHECKED	APPROVED
4	00746 - DRAWING BORDER FORMAT UPDATED. 364 594 011 LENGTH - 16000/15950 REMOVED FROM TABLE. 364 594 021 ADDED TO TABLE	2020-12-16	AJW	MC028	WS144

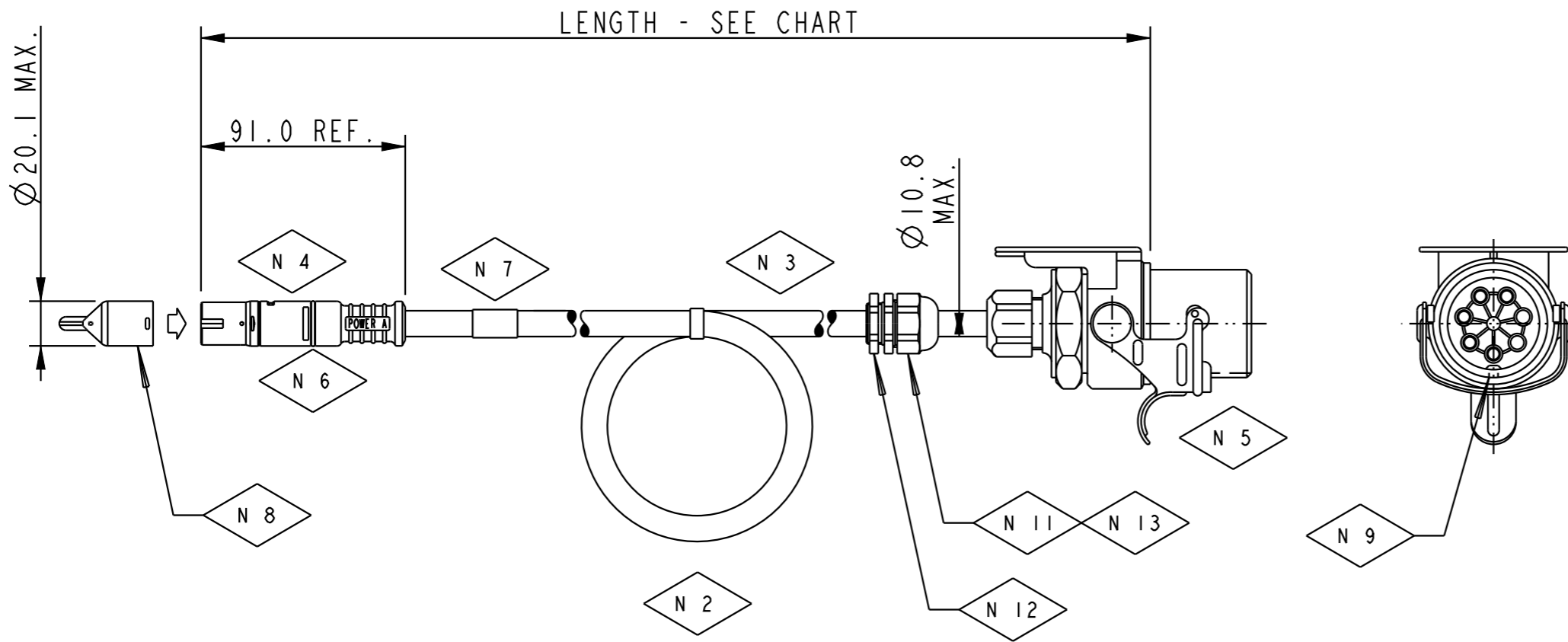

- N 1 SEE CHART 'A' FOR CABLE ASSEMBLY PART NUMBER.
- N 2 CABLE IS SUPPLIED COILED IN A PLASTIC BAG AS SHOWN.
- N 3 CABLE INSULATION MATERIAL - PVC
WIRE CROSS SECTIONAL AREA - 3x1.5mm² AND 2x4.0mm².
- N 4 CONFORMS TO IP67 (BS EN 60529) WHEN MATED WITH MATED WITH UABS ECU / JUNCTION BOX.
- N 5 CONFORMS TO IP67 (BS EN 60529) WHEN MATED WITH MATED ISO 7638 SOCKET ASSEMBLY.
- N 6 SEAL TO BE PROTECTED FROM DAMAGE PRIOR TO ASSEMBLY
- N 7 PART NUMBER IDENTIFICATION.
- N 8 PROTECTIVE CAP - DO NOT REMOVE UNTIL FITMENT TO UABS ECU / JUNCTION BOX.
- N 9 KEY SLOT POSITION DENOTES 24V SYSTEM.
- N 10 VIEW SHOWING WIRES ON WIRING SIDE OF CONNECTOR.
- N 11 POSITION OF LOCKING NUT TO BE DETERMINED BY THE CUSTOMER.
- N 12 NUT TO BE TIGHTENED TO A TORQUE OF 3.5/3.0Nm.
- N 13 GLAND TO BE TIGHTENED TO A TORQUE OF 4.0/3.5Nm.

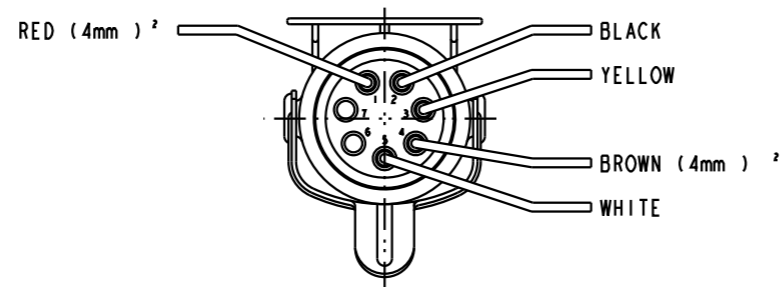

CHART 'A'	
ASSY NO.	LENGTH(MIN)
364 594 001	6m
364 594 011	16m
364 594 021	12.5m

TOLERANCE UNLESS OTHERWISE SPECIFIED N/A	DOC TYPE DRAFT	SCALE N/A	MATERIAL N/A		
THIS DOCUMENT USES SPECIAL CHARACTERISTICS AS DEFINED IN PROCEDURE HDX2-3-364	DRAWN MPH	DATE 2012-07-24	WEIGHT (ONLY FOR INFO.) N/A	DIMENSION IN N/A DO NOT SCALE DRAWING	
	CHECKED JPH	DATE 2013-08-15	TITLE UABS ISO 7638 PLUG ASSY 24V - UNFUSED (POWER A - IN)		
 HALDEX BRAKE PRODUCTS LTD MIRA TECHNOLOGY PARK	APPROVED JPH	DATE 2013-08-15	ITEM NUMBER 364 594 000 2	PROJECTION 	SHEET 1(1)
				FORMAT A3	

GENERIC MODEL (INFO ONLY): mdl.generic.name