

PART No.
814 032 000 2

COMPUTER PRODUCED DRAWING
MUST NOT BE CHANGED MANUALLY

- N 1 SEE CHART A FOR CABLE ASSEMBLY PART NUMBER.
- N 2 CABLE IS SUPPLIED COILED IN A PLASTIC BAG
- N 3 CABLE INSULATION MATERIAL - PVC WIRE CORE CROSS SECTIONAL AREA - 0.75mm²
- N 4 REFER TO INSTALLATION/SERVICE MANUAL FOR TAG REMOVAL
- N 5 CONFORMS TO IP67 (BS EN 60529) WHEN MATED WITH EB+ ECU/ Y-SPLITTER

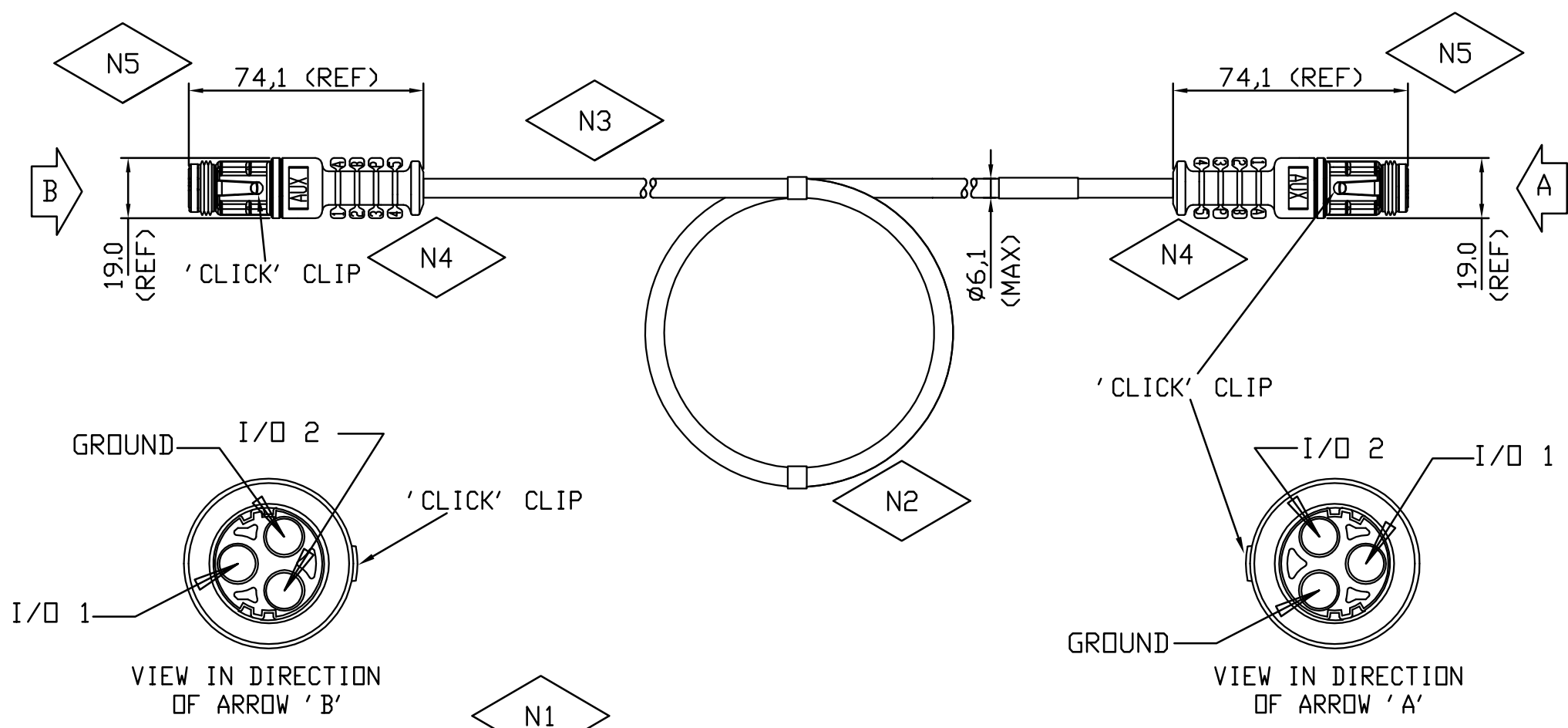

CHART A		
ASSY NO	LENGTH	CABLE MATERIAL
814 032 001	1 M	PVC
814 032 011	4 M	PVC
814 032 021	7 M	PVC
814 032 031	18 M	PVC

K **T** **M**
THIS DRAWING/SPECIFICATION USES CLASSIFIED CHARACTERISTIC SYMBOLS DEFINED IN QUALITY PROCEDURE 4.17

1	PR2090	GIL	01.07.11				
ISS	CHANGE	CHEC	DATE	ISS	CHANGE	CHEC	DATE

AutoCAD PART
THIS DRAWING/DOCUMENT IS COPYRIGHT AND THE PROPERTY OF HALDEX BRAKE PRODUCTS LIMITED. IT MUST NOT BE COPIED (IN WHOLE OR IN PART) USED FOR MANUFACTURE OR OTHERWISE DISCLOSED WITHOUT PRIOR WRITTEN CONSENT OF THE COMPANY. ANY COPIES OF THIS DRAWING/DOCUMENT MADE BY ANY METHOD MUST ALSO INCLUDE A COPY OF THIS LEGEND. © 2011

NOTE: UNLESS OTHERWISE STATED THE FOLLOWING APPLIES
1 ISO METHOD A PROJECTION.
2 S.I. UNITS.
3 SURFACE FINISH TO BS 308/BS 1134.
4 DIMS. APPLY AFTER CHEMICAL OR ELECTRO-PLATED FINISH.
5 WELD SYMBOLS TO BS 499.
6 D DATUM DIMENSIONS.
7 METRIC THREADS TO BS 3643/DIN 13.
8 UNIFIED THREADS TO BS 1580.

ASSOC SPECS.			
MATERIAL	DRAWN	DATE	
HEAT TREATMENT	G LEDINGHAM	01.07.11	
FINISH	CHECKED	DATE	
FORM	JPH	04/08/11	
	APPROVED SPECIALIST	DATE	
	JPH	04/08/11	
	APPROVED FOR ISSUE	DATE	
	JPH	04/08/11	

TITLE
3 POLE AUXILIARY TO
3 POLE AUXILIARY CABLE
ASSEMBLY CHART
SCALE WAS -
NTS SHEET 1 OF 1

HALDEX BRAKE PRODUCTS LTD
MOONS MOAT DRIVE,
REDDITCH, WORCS.
B98 9HA
PART No.
814 032 000 2
A3

