

PART No. 003 8998 09

STAGE 1

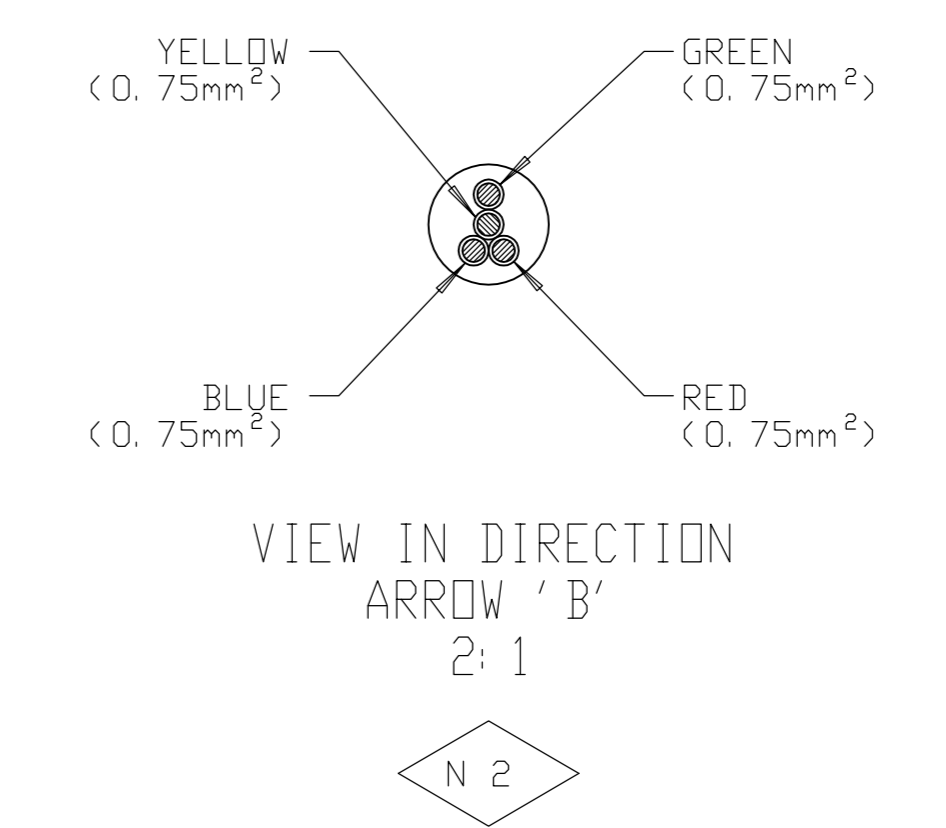
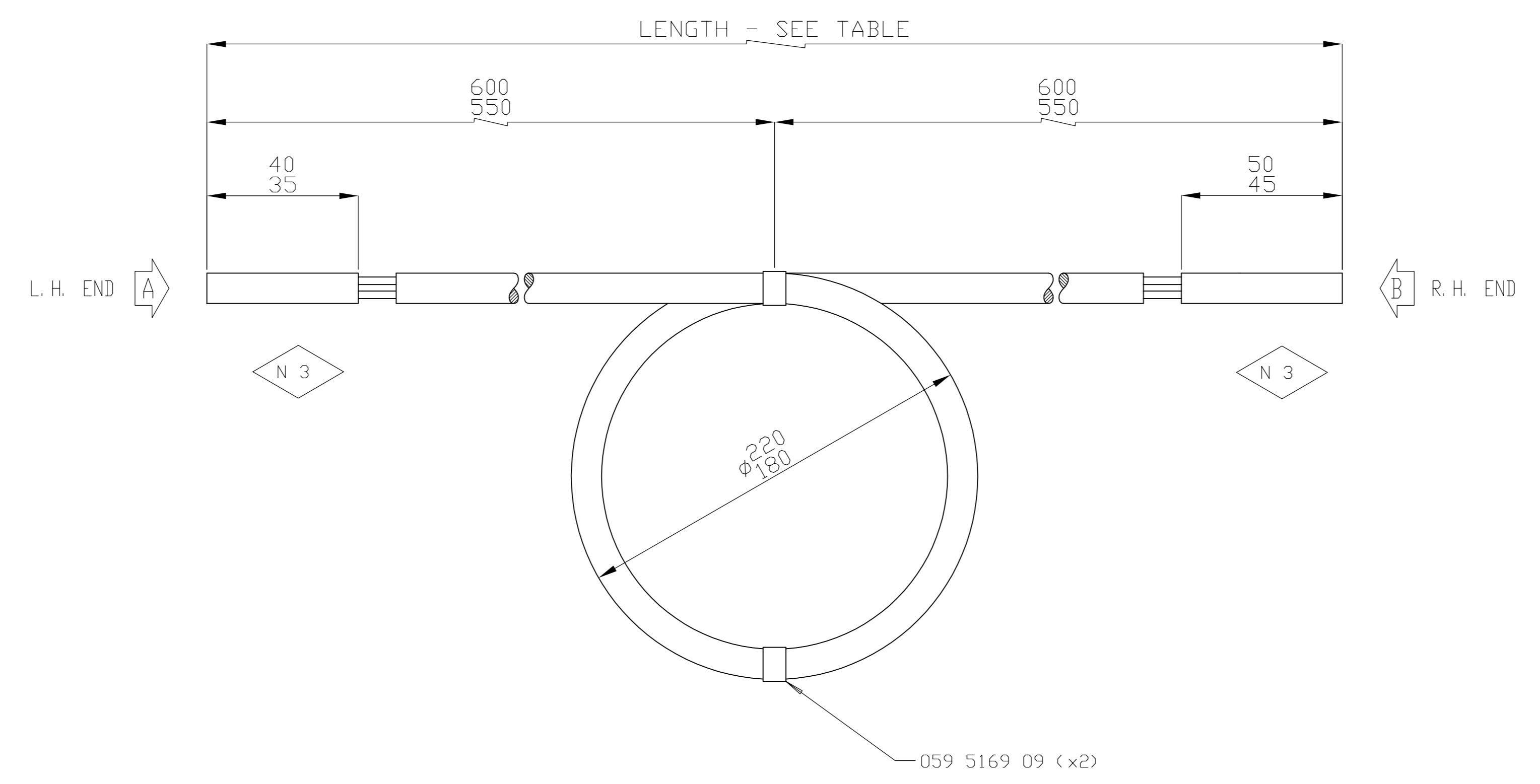
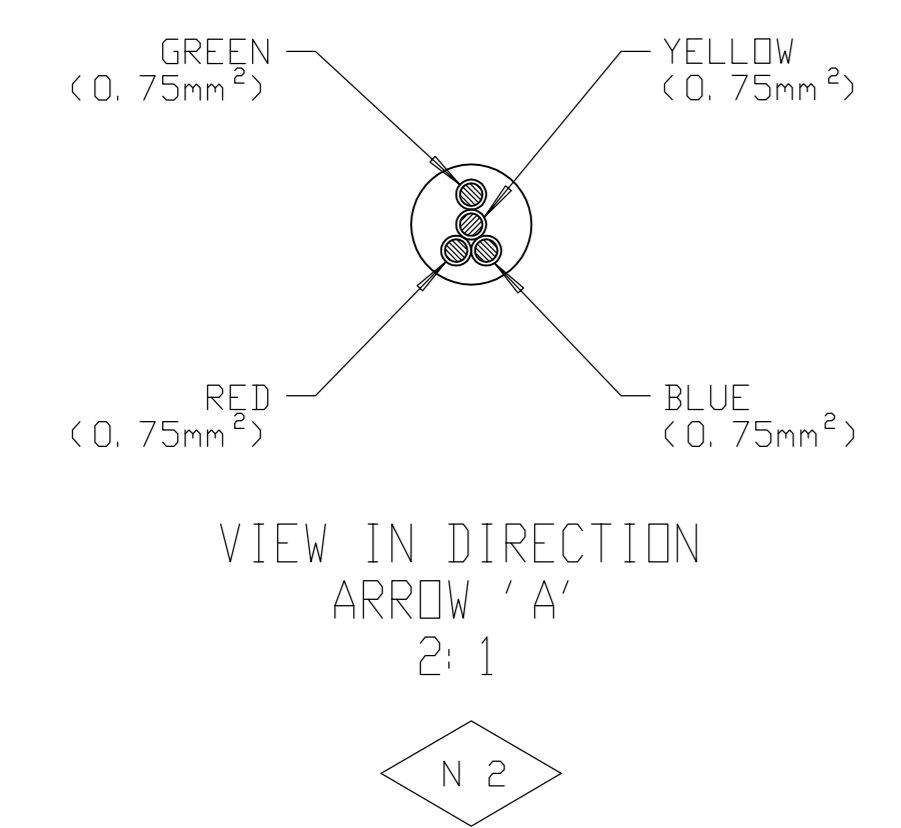

COMPUTER PRODUCED DRAWING
MUST NOT BE CHANGED MANUALLY

- N 1 MAKE FROM CABLE 059 5244 09 (PVC).
- N 2 PRIOR TO STRIPPING CABLE ENSURE ORIENTATION OF CORE COLOURS AS SHOWN.
- N 3 STRIP OUTER SHEATH ONLY LEAVING INSULATION AS SHOWN TO PROTECT CORES.
- N 4 WIRE PREPARATION TO SPEC'N GS0216.
- N 5 IF OVERMouldING FAILS TO CONFORM TO QUALITY CONTROL REQUIREMENTS, CUT OFF SHORT AND RE-MOULD. RE-MOULD ONCE ONLY.
- N 6 ASSEMBLE LARGEST DIAMETER TOWARDS CABLE.
- N 7 WIRE CRIMPING TO SPEC'N GS0217.
- N 8 WIRE CRIMPING (PASS OFF) TO SPEC'N GS0218.
- N 9 KEY POSITION.
- N10 PRIOR TO ASSEMBLY.
- N11 ENSURE PLUGS ARE FIRMLY ENGAGED IN SOCKET.
- N12 FOR OVERMouldING DETAIL SEE 027 5150 09.
- N13 FIT PROTECTIVE CAP AFTER OVERMouldING.
- N14 PRINT PART No. AND MD No. ON LABEL. WRAP LABEL ROUND CABLE AS SHOWN ENSURING CLEAR FILM OVERWRAPS THE PRINTING.
- N15 TEST FINAL ASSY. TO GS0082 AND GS0197.

LEFT HAND END
STAGE 2

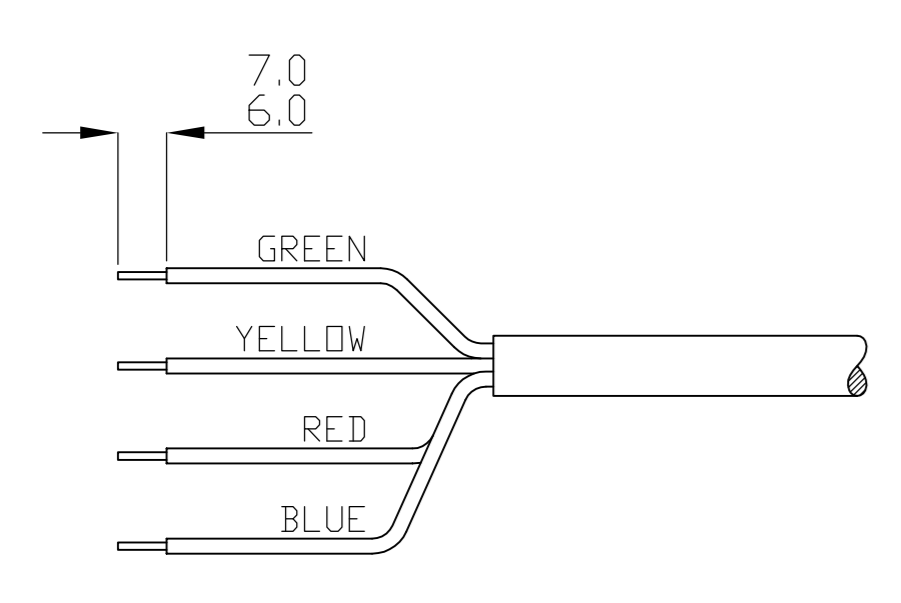

RIGHT HAND END
STAGE 2

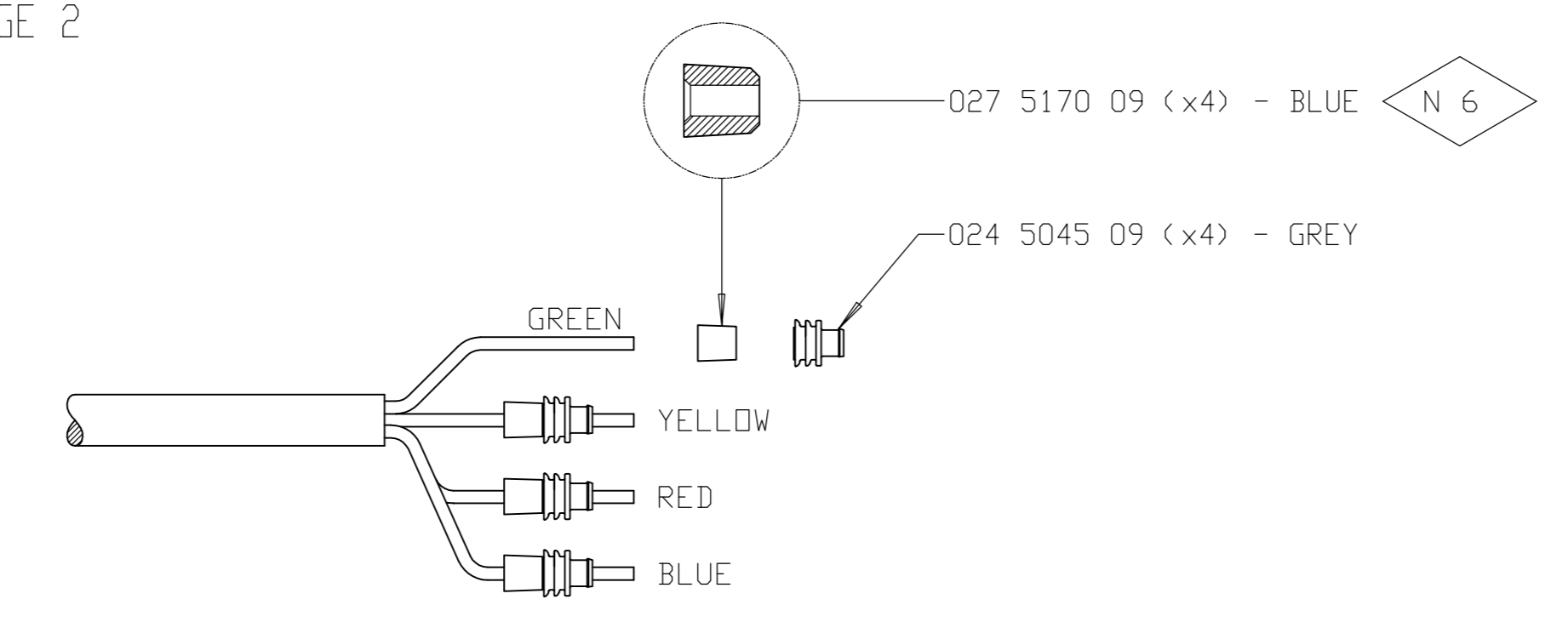

RIGHT HAND END
STAGE 3

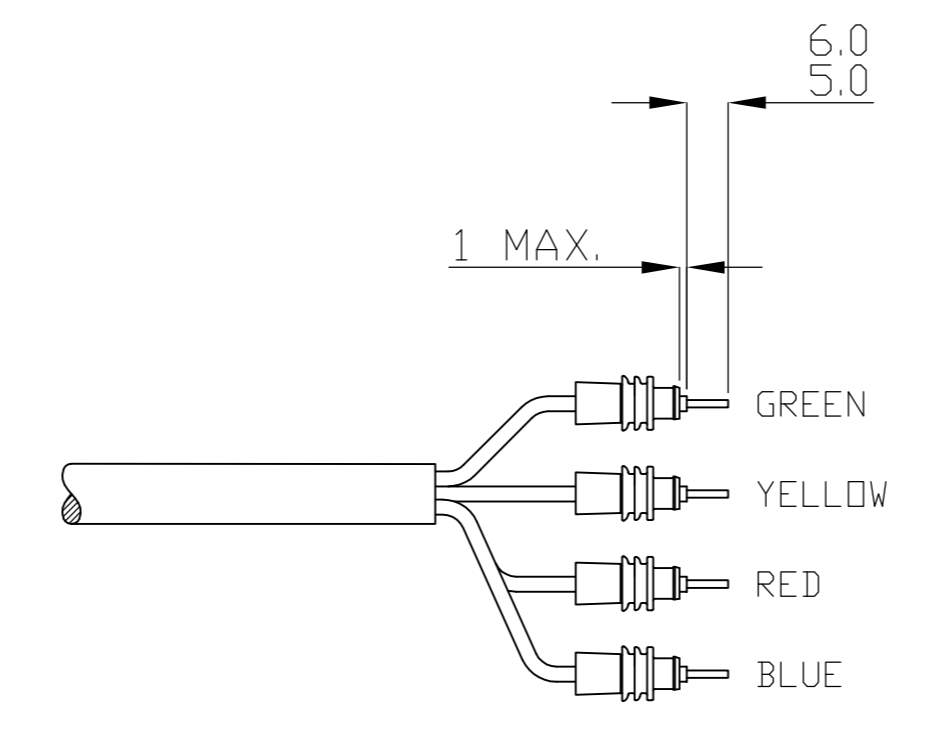

RIGHT HAND END
STAGE 4

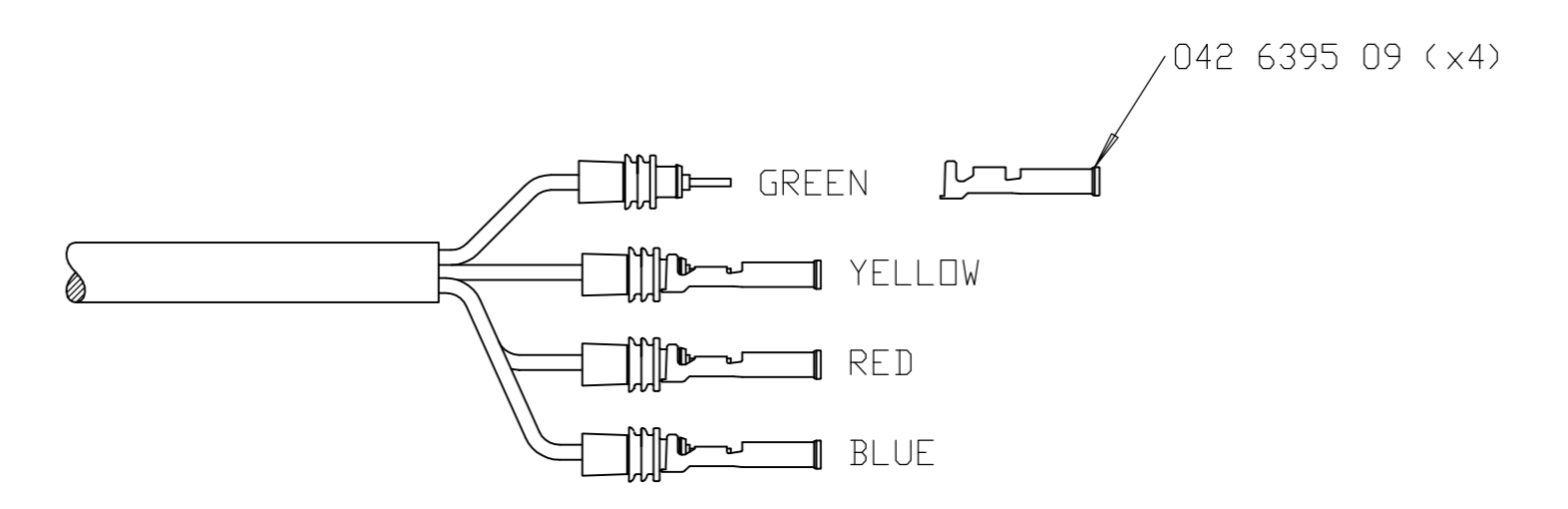

RIGHT HAND END
STAGE 5
2:1

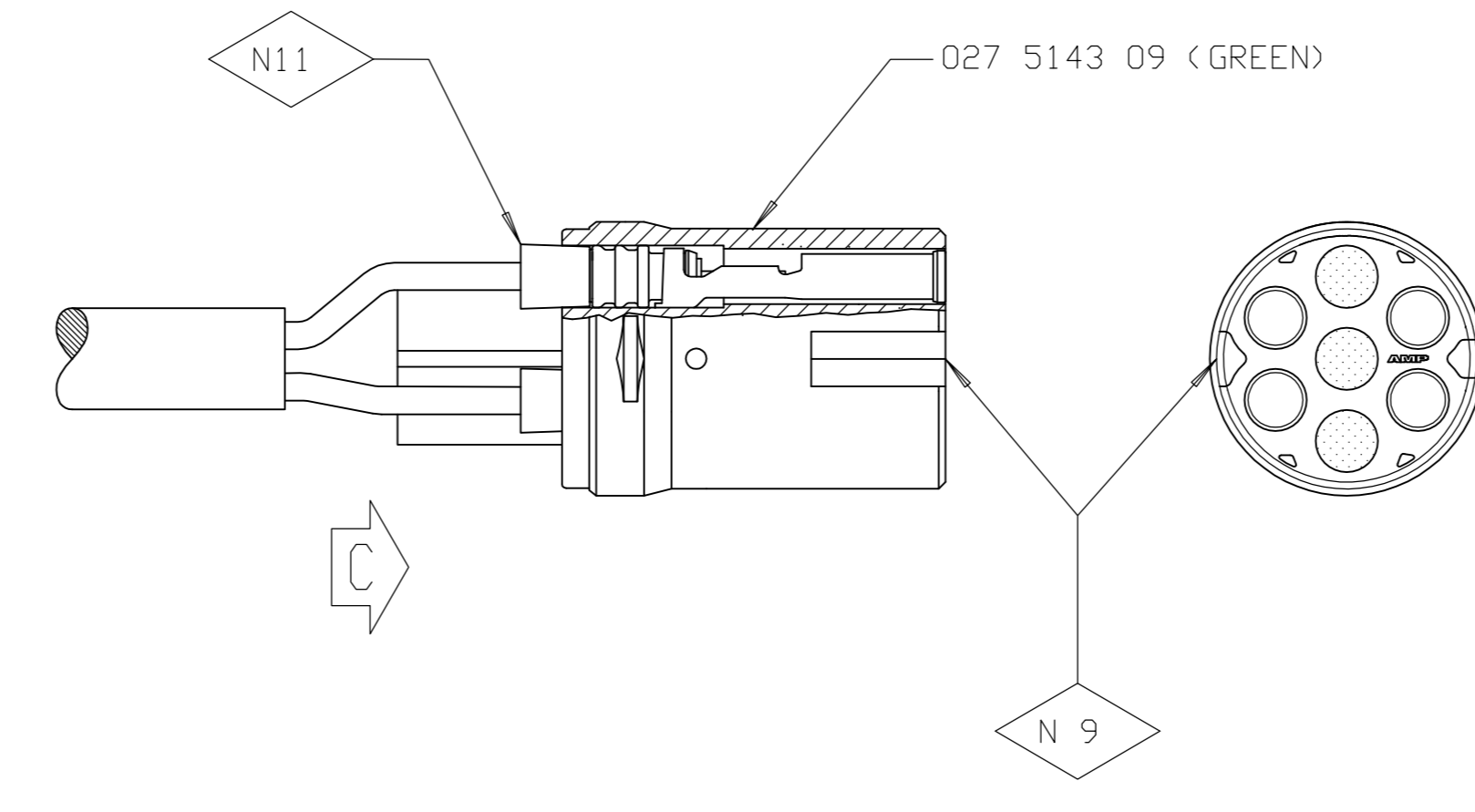
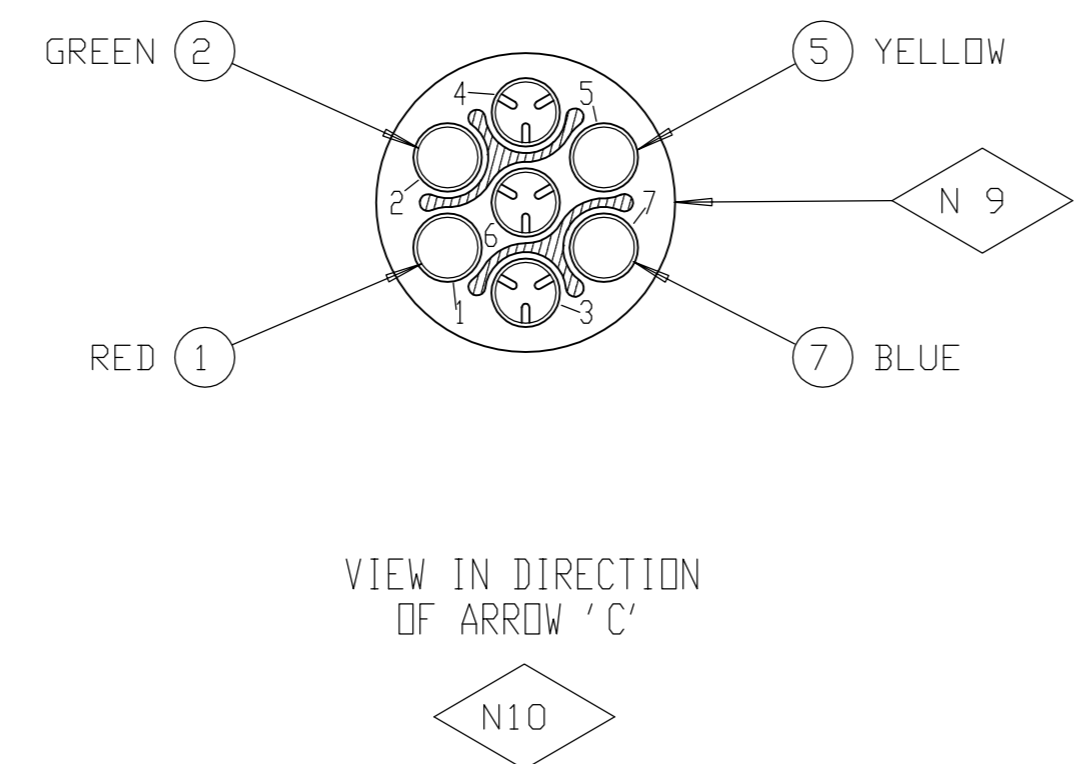

RIGHT HAND END
STAGE 6

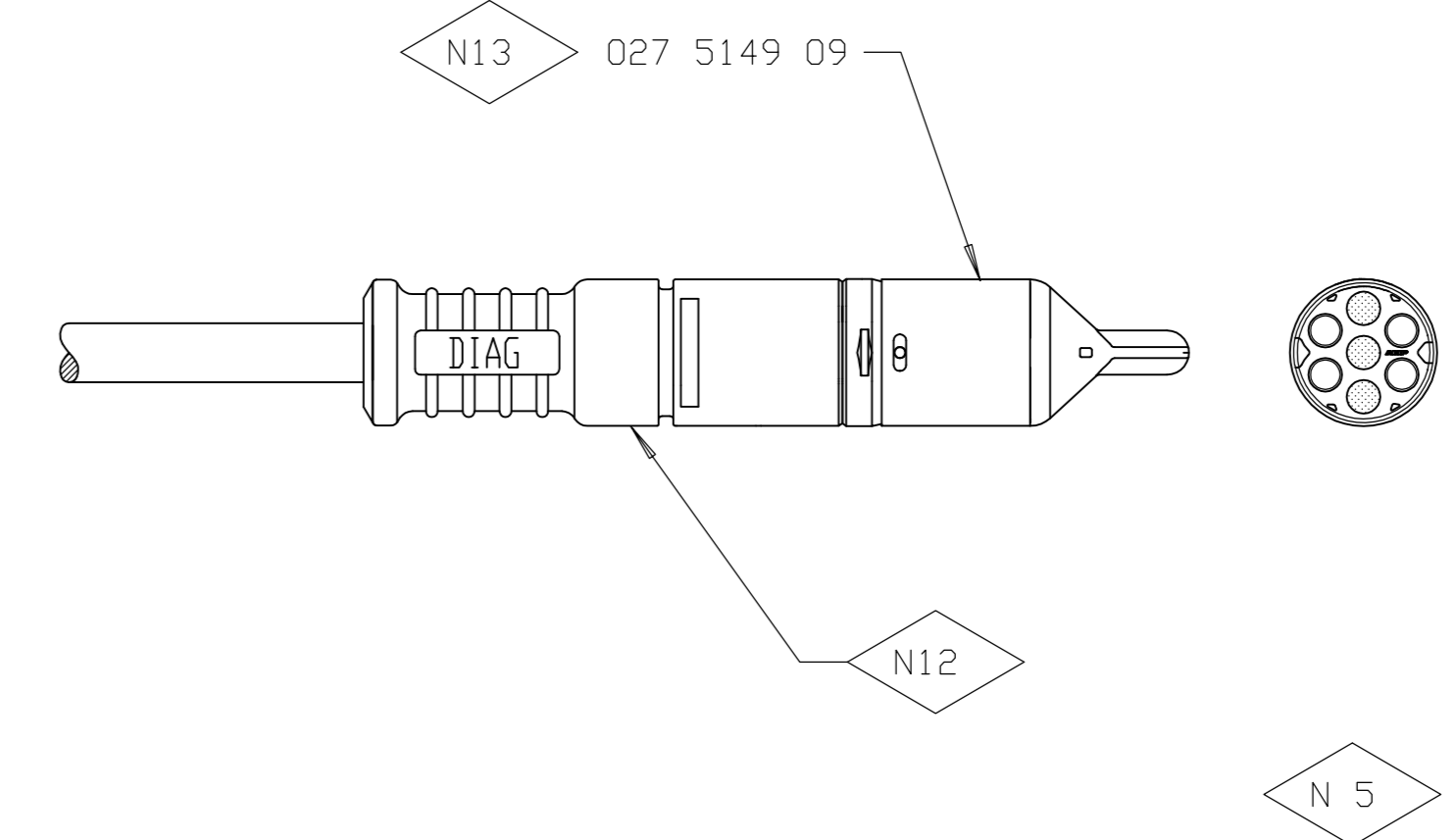

FINAL ASSEMBLY

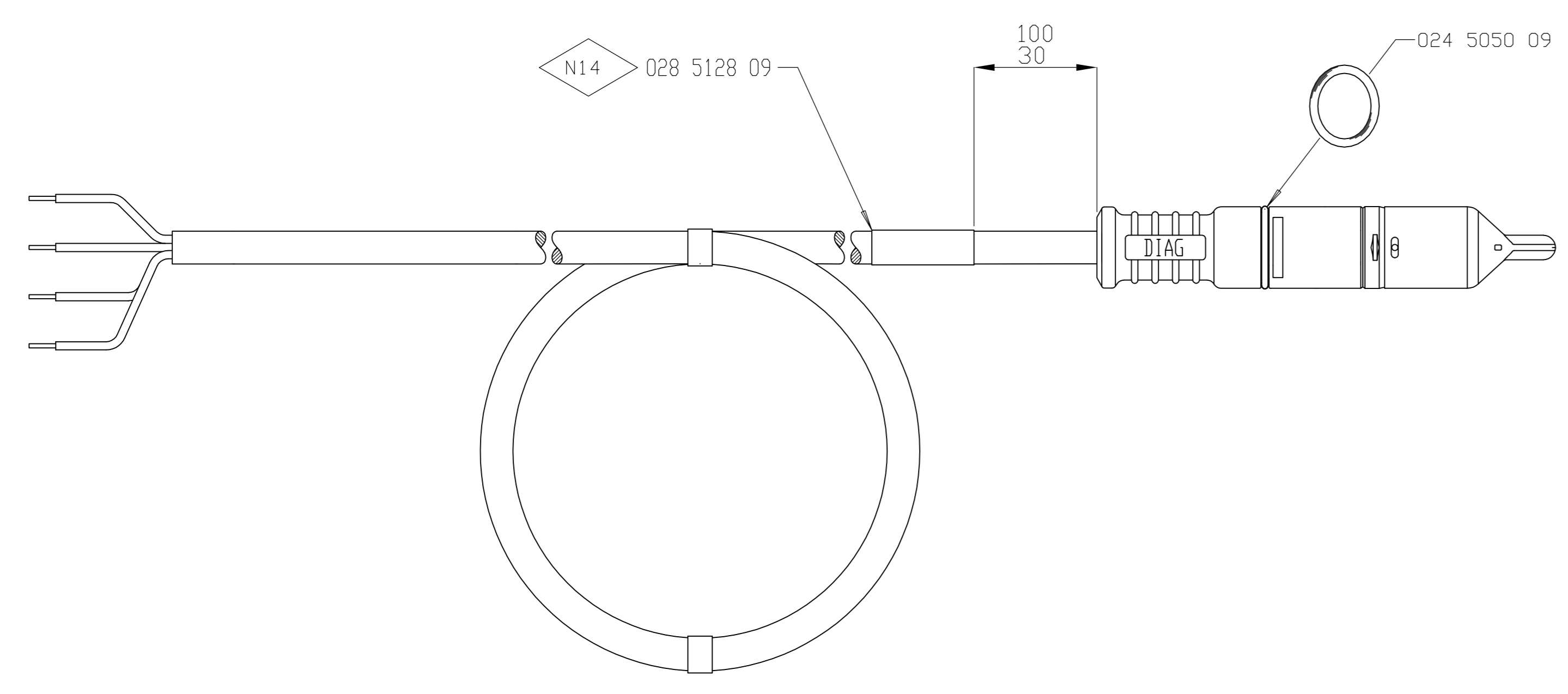

ASSY. No.	CUT LENGTH	ISS.	CHANGE	DATE
003 8987 09	6700/6500	1	PR1605	17-05-04
003 8996 09	12200/12000	2	C5137	25-05-07

THIS DRAWING/DOCUMENT IS COPYRIGHT AND THE PROPERTY OF HALDEX BRAKE PRODUCTS LIMITED. IT MUST NOT BE COPIED (IN WHOLE OR IN PART) USED FOR MANUFACTURE OR OTHERWISE DISCLOSED WITHOUT PRIOR WRITTEN CONSENT OF THE COMPANY. ANY COPIES OF THIS DRAWING/DOCUMENT MADE BY ANY METHOD MUST ALSO INCLUDE A COPY OF THIS LEGEND.

NOTE: UNLESS OTHERWISE STATED THE FOLLOWING APPLIES
 1. ISO METHOD A PROJECTION
 2. S.I. UNITS.
 3. SURFACE FINISH TO BS 308/BS 1134.
 4. DIMS. APPLY AFTER CHEMICAL OR ELECTRO-PLATED FINISH.
 5. WELD SYMBOLS TO BS 499.
 6. DIM. DATUM DIMENSIONS.
 7. METRIC THREADS TO BS 3643/DIN 13.
 8. UNIFIED THREADS TO BS 1580.

ASSOCIATED SPECIFICATIONS	MATERIAL
GS 0082	-
GS 0197	HEAT TREATMENT
GS 0216	-
GS 0217	FINISH
GS 0218	FORM

DRAWN	DATE	TITLE
DAVID SKIPPER	17-05-04	TTM EB+ CABLE CHART
CHECKED	03/10/11	
APPROVED SPECIALIST	DATE	ORIGINAL SCALE
JPH	03/10/11	1:1
APPROVED FOR ISSUE	DATE	SHEET 1 OF 1
JPH	03/10/11	

THIS DRAWING/SPECIFICATION USES CLASSIFIED CHARACTERISTIC SYMBOLS DEFINED IN QUALITY PROCEDURE 4.17

ISS	CHANGE	CHEC	DATE	ISS	CHANGE	CHEC	DATE
4	C6091	MPH	08-08-11				
3	C5180	HSU	31-07-08				
2	C5137	CGS	25-05-07				
1	PR1605	DMS	17-05-04				

Haldex
 HALDEX BRAKE PRODUCTS LTD.
 MOONS HOLT DRIVE, REDDITCH, WORCS. B98 7HA.
 PART No. 003 8998 09