

PART No. 814 001 000 2

COMPUTER PRODUCED DRAWING
MUST NOT BE CHANGED MANUALLY

- N 1 CABLE ASSEMBLY SUPPLIED IN COILED CONDITION AS SHOWN.
- N 2 PROTECTIVE CAP - DO NOT REMOVE UNTIL FITMENT TO ECU.

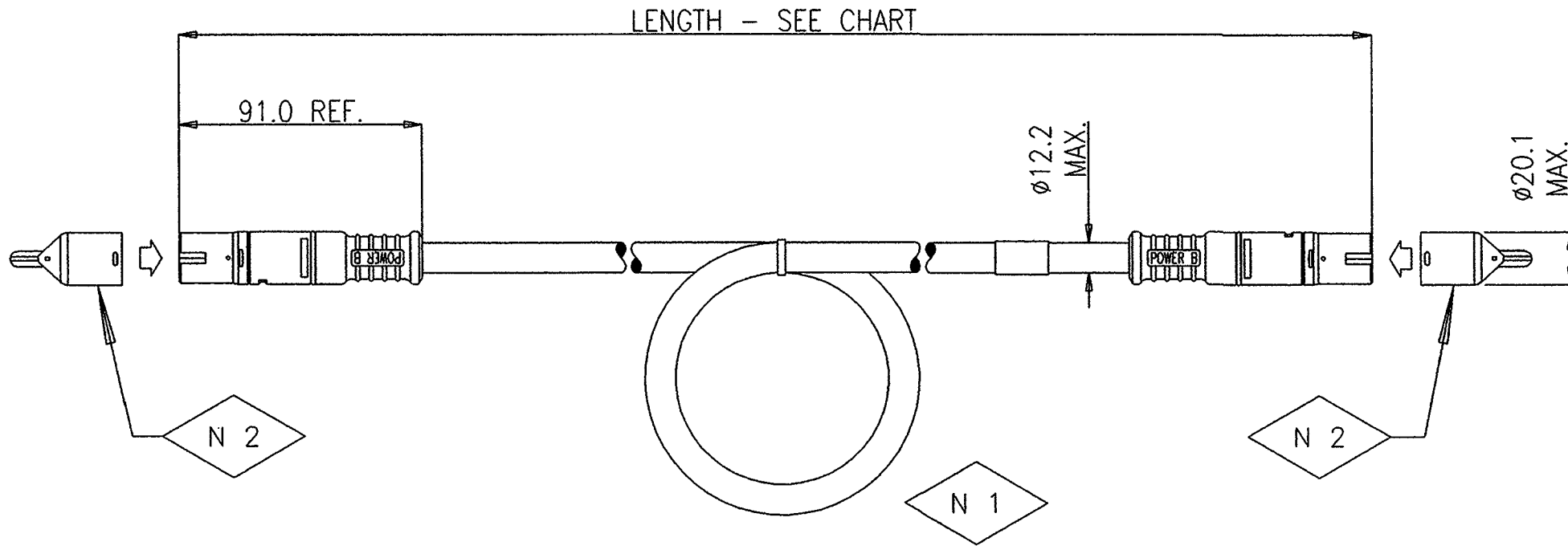

CABLE MATERIAL - PUR		
HALDEX ASSY No	BPW ASSY No	LENGTH (MIN)
814 001 001	-	12m
814 001 011	-	2m
814 001 021	-	5m
814 001 031	-	14m
814 001 041	-	10m
814 001 051	-	8m

CABLE MATERIAL - PVC		
HALDEX ASSY No	BPW ASSY No	LENGTH (MIN)
814 001 002	02.1833.03.05	12m
814 001 012	02.1833.03.01	2m
814 001 022	02.1833.03.02	5m
814 001 032	02.1833.03.06	14m
814 001 042	02.1833.03.04	10m
814 001 052	02.1833.03.03	8m

THIS DRAWING/SPECIFICATION USES CLASSIFIED CHARACTERISTIC SYMBOLS DEFINED IN QUALITY PROCEDURE 4.17

ISS	CHANGE	CHEC	DATE	ISS	CHANGE	CHEC	DATE
6	C5485	HSU	27.10.08				
5	C5155	RCM	12-03-07				
4	C4624	CGS	07-10-04				
3	C4525	DMS	13-05-04				
2	C4377	CGS	12-08-03				
1	PR1490	CGS	14-01-03				

THIS DRAWING/DOCUMENT IS COPYRIGHT AND THE PROPERTY OF HALDEX BRAKE PRODUCTS LIMITED. IT MUST NOT BE COPIED (IN WHOLE OR IN PART) USED FOR MANUFACTURE OR OTHERWISE DISCLOSED WITHOUT PRIOR WRITTEN CONSENT OF THE COMPANY. ANY COPIES OF THIS DRAWING/DOCUMENT MADE BY ANY METHOD MUST ALSO INCLUDE A COPY OF THIS LEGEND. © 2003

- NOTE: UNLESS OTHERWISE STATED THE FOLLOWING APPLIES
- 1 ISO METHOD A PROJECTION.
 - 2 S.I. UNITS.
 - 3 SURFACE FINISH TO BS 308/BS 1134.
 - 4 DIMS. APPLY AFTER CHEMICAL OR ELECTRO-PLATED FINISH.
 - 5 WELD SYMBOLS TO BS 499.
 - 6 D DATUM DIMENSIONS.
 - 7 METRIC THREADS TO BS 3643/DIN 13.
 - 8 UNIFIED THREADS TO BS 1580.

ASSOC SPECS.	-		
MATERIAL	-	DRAWN CGSpracklen	DATE 14-01-03
HEAT TREATMENT	-	CHECKED R. Malholly	DATE 3-6-09
FINISH	-	APPROVED SPECIALIST	DATE
FORM	-	APPROVED FOR ISSUE R. Malholly	DATE 3-6-09

TITLE
EB+
3M LINK CABLE ASSEMBLY
(POWER B - POWER B)

ORIGINAL SCALE
WAS
SHEET 1 OF 1

HALDEX BRAKE PRODUCTS LTD
MOONS MOAT DRIVE,
MOONS MOAT NORTH,
REDDITCH, WORCS.
B98 9HA

Part No. 814 001 000 2