

International Aftermarket EGP Valve Installation Instructions

L31244

6/09

Haldex

These instructions are to replace a standard height control valve with dump with the EGP height control valve on International Trucks. The installation requires a mounting hole conversion bracket. In addition the ride height and linkage may also require adjustment after the EGP HCV is installed. Please read and understand these instructions and the EGP valve instructions, L31186.

Replacement Instructions

Verify the installation according to Figures 1,2 and 3 and use the appropriate plumbing shown in Figure 4 or 5 for your application.

- 1) Screw in air spring and air supply fittings to EGP valve as shown in Figure 1.
- 2) Position the valves alignment indicator as shown in Figure 1. Refer to L31186 for more information.
- 3) When the control arm is in the proper location torque the locking bolt to 6-8ft-lbs.
- 4) Ensure all pressure in system is depleted.
- 5) Disconnect air lines from the valve being replace. Mark the lines for air supply, air springs, and dump for the following steps.
- 6) Remove linkage from control arm of current valve.
- 7) Mount the conversion bracket to the original valve bracket as shown in Figure 2(on reverse side).
- 8) Mount the EGP HCV as shown in Figure 2 (on reverse side) to the conversion bracket. Torque to 35-40 in-lbs.
- 9) Assemble linkage to axle and EGP control arm as shown in Figure 2 (on reverse side).
- 10) Connect air lines to the EGP HCV using the markings from step 5. The port locations are shown in Figure 1 and Figure 3 (on reverse side).
- 11) Refer to L31186 for ride height adjustment, maintenance and other detailed installation information.

WARNING: Linkage and ride height may need to be adjusted when changing height control valve suppliers. It is the responsibility of the installer to check for the recommend ride height and linkage after installing the Haldex HCV.

Figure 1

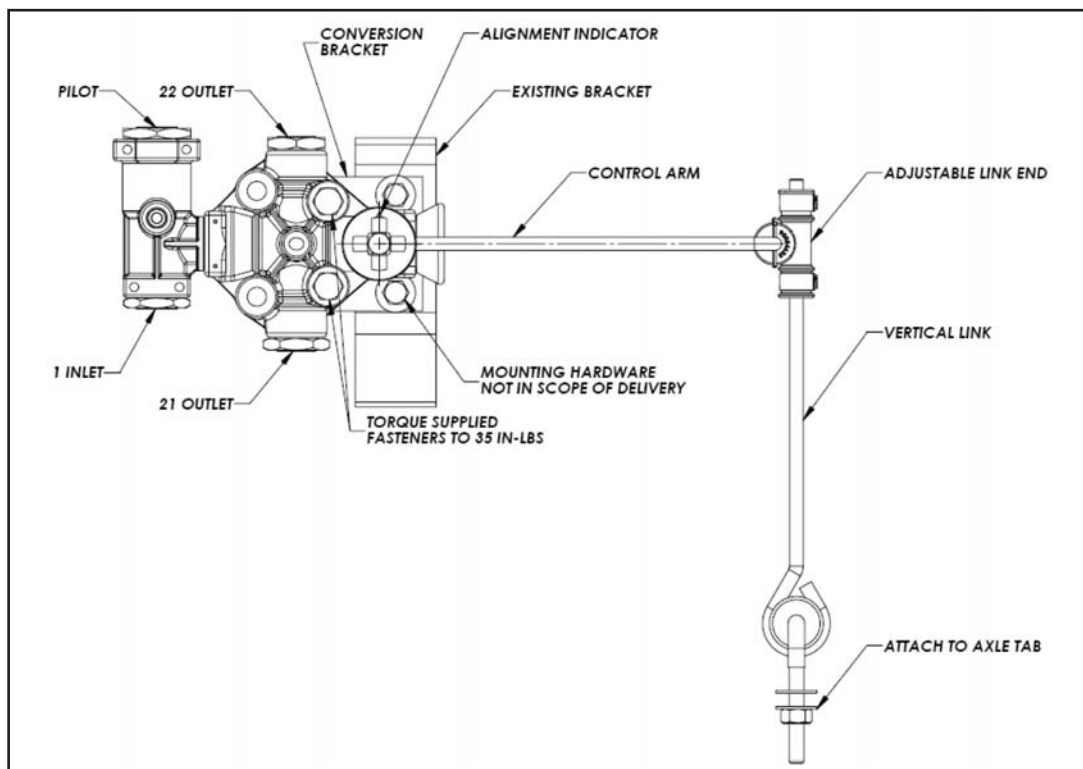

Figure 2

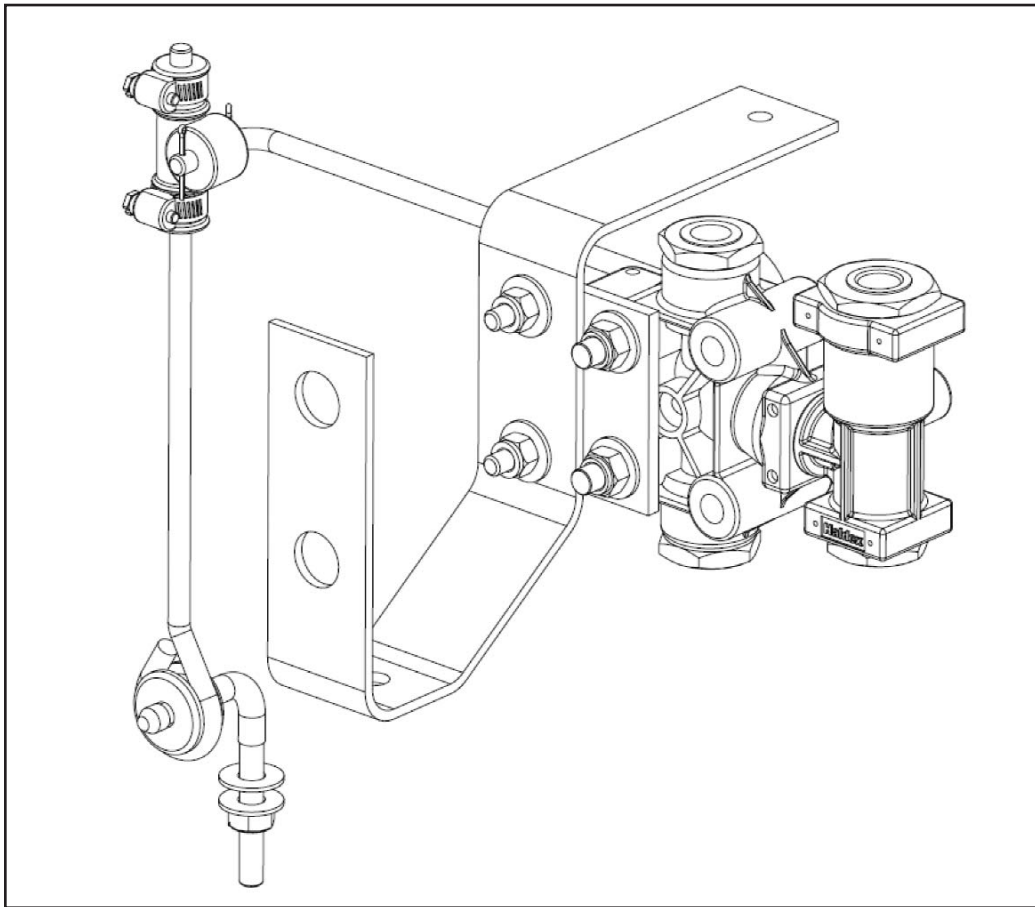
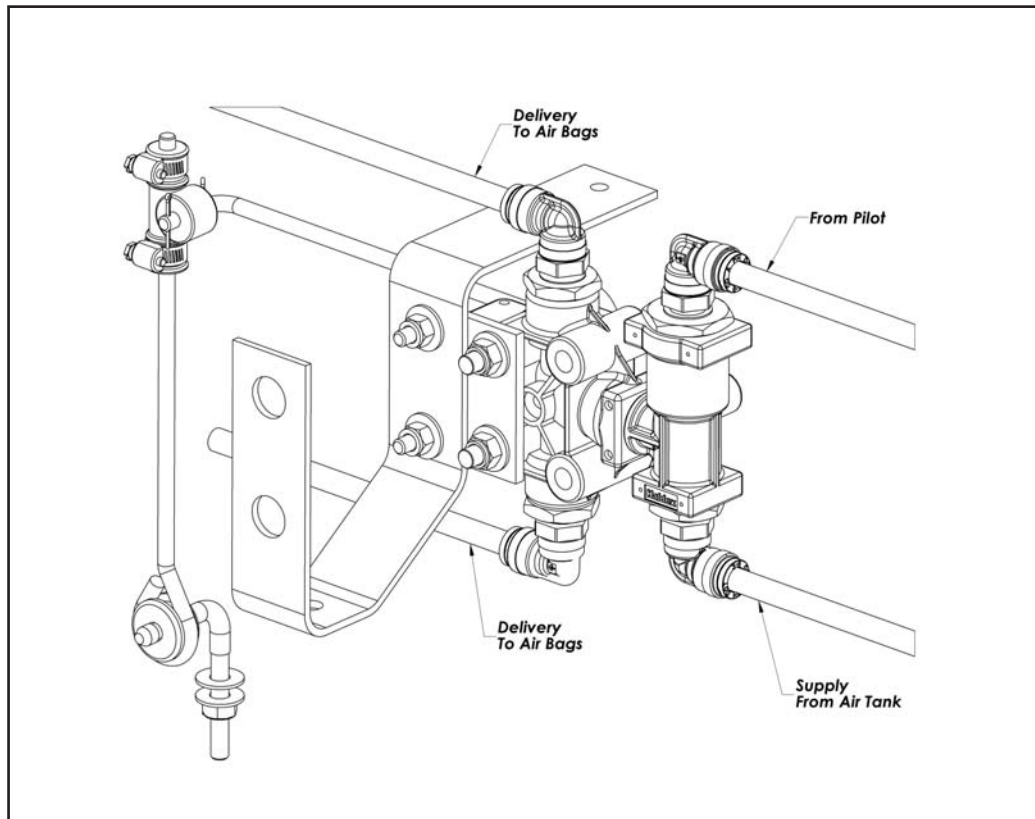

Figure 3



Haldex Commercial Vehicle Systems



**Haldex Brake
Products Corporation**
10930 N. Pomona Ave.
Kansas City, MO 64153-1256
Phone: 816-891-2470
Fax: 816-891-9447

Haldex Limited
525 Southgate Drive, Unit 1
Guelph, ON
Canada N1G 3W6
Phone: 519-826-7723
Fax: 519-826-9497