

Recommended procedure for cutting brake chamber pushrod

(Service brake chamber or double diaphragm spring brake chamber)

This procedure is applicable to Haldex automatic and all manual brake adjusters



WARNING: Always chock wheels to prevent vehicle from moving. Vent vehicle system air pressure to zero psi.

- A. When preparing to install a spring brake chamber, ensure that the unit is fully released (power spring caged) and the service brake pushrod is fully retracted to zero stroke position. Thread the clevis jam nut onto the pushrod.
- B. Place the brake chamber into the appropriate brake assembly bracket. Tighten the holding nuts to the bracket studs (100–140 lb. ft.).
- C. Measure the distance from the centerline of the S-Cam to the centerline of the pushrod (See Figure 2 - Dimension A). This measurement should be equal to the length of the brake adjuster being used. (See Figure 3 - Dimension A).

NOTE: If Dimension A - Figure 2 and Dimension A - Figure 3 are not identical, the chamber mounting bracket is either bent and must be straightened or replaced, the chamber has been mounted improperly in the bracket or the length of the adjuster installed is incorrect. Make any necessary corrections before going to Step D.

- D. Measure and record the length of clevis to be used. This measurement should be taken from the center of the clevis pin hole, to the bottom of the yoke assembly. (See Figure 1).
- E. Using a square, mark the pushrod at the 90° setting (See Figure 2 - Mark #1). From this mark, subtract the measurement recorded in Step D and make a second mark on the pushrod (moving toward the brake chamber mounting surface). (See Figure 2 - Mark #2).
- F. From Mark #2, measure toward the brake chamber mounting surface the distance listed in Table 1 - Column "D" (See Reverse Side) for the brake chamber type being installed. **Mark and cut the pushrod.**
- G. Install the clevis onto the pushrod and secure the jam nut (33–90 lb. ft.). Connect the clevis to the brake adjuster using the clevis pin and cotter pins (See Figure 1). Uncage the spring brake.
- H. Release spring brakes and adjust the brake adjuster to the manufacturer's recommendation.

Figure 1

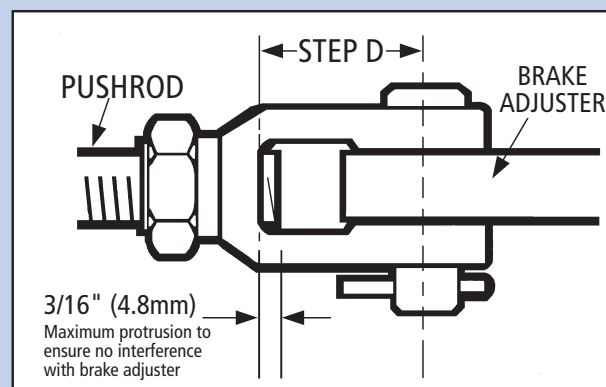

Figure 2

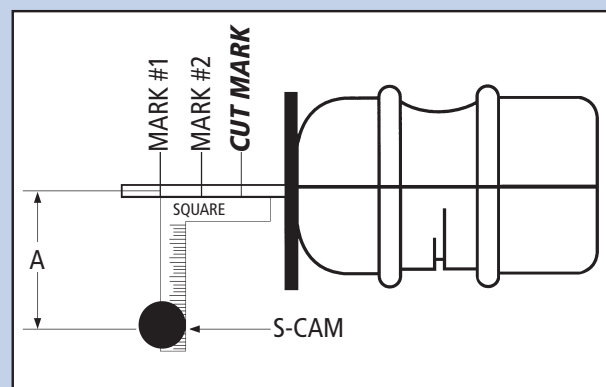
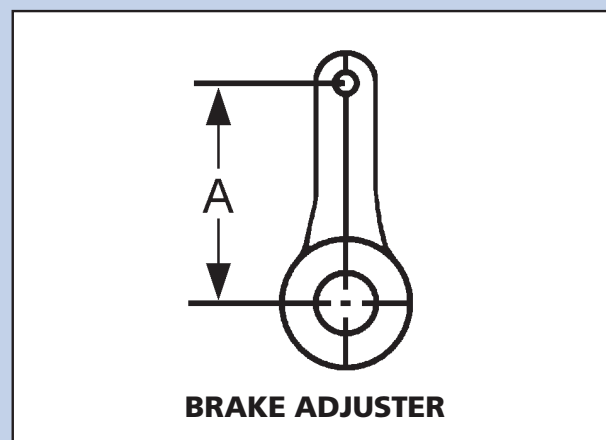

Figure 3



Recommended procedure for cutting brake chamber pushrod

(Service brake chamber or double diaphragm spring brake chamber)

Important Note: Some automatic brake adjusters require a slightly different rod length. Always refer to the original manufacturer's installation guidelines.

Table 1 - Stroke Values

Column A	Column B	Column C	Column D
Chamber Type	Available Stroke	"Maximum" Readjustable Stroke	Set-Up Stroke
09	1 3/4"	1 3/8"	1 3/8"
12	1 3/4"	1 3/8"	1 3/8"
16	2 1/4"	1 3/4"	1 3/8"
20	2 1/4"	1 3/4"	1 3/8"
20LS*	2 1/2"	2"	1 1/2"
24	2 1/4"	1 3/4"	1 3/8"
24LS*	2 1/2"	2"	1 1/2"
24XLS**	3"	2 1/2"	1 3/4"
30	2 1/2"	2"	1 1/2"
30LS*	3"	2 1/2"	1 3/4"
36	3"	2 1/4"	1 3/4"

*Long Stroke **Extra Long Stroke

! DANGER:

A spring brake or combination service/spring brake must be disarmed before disposal, or forceful release of the compression spring may occur in the future without warning.

WARNING: Haldex strongly recommends routine visual checks be performed at EACH maintenance service interval. Foundation brake operational checks utilizing CVSA level 1 applied stroke criteria should always be utilized. Manual adjustment of automatic adjusters can disguise hidden problems within the foundation brake. Brake components such as s-cams, bushings, return springs, actuators, drums and adjuster installation MUST be within manufacturer's specifications. Adjuster control arms, wear bushings or attaching hardware that demonstrate visual damage, or which fail the operational checks, MUST be replaced immediately. Automatic Adjusters should NEVER be operated as manual adjusters except as may be necessary to get the vehicle off the road for service.