

Part Numbers for Components Shown Above

	Part #
PR Height Control Valve with Dump	90554950
PR Height Control Valve without Dump	90554945
Pressure Protection Valve	90554107
Height Control Linkage	48100375
Colas Raise Lower Valve	90555270



Commercial Vehicle Systems

North American Sales Division
Haldex Brake Products Corporation
10707 NW Airworld Drive
Kansas City, MO 64153-1215
Phone: 816-891-2470
Fax: 816-801-4198

North American Sales Division
Haldex Limited
525 Southgate Drive, Unit 1
Guelph, Ontario Canada N1G 3W6
Phone: 519-826-7723
Fax: 519-826-9497

www.haldex.com www.hbsna.com



Installation Instructions for the Colas Valve

General Information

The Colas Valve is used for manually raising and lowering the deck height of commercial vehicles and trailers.

Operation

Position “drive”

When the lever is in the central position it may be pulled out. In this position the valve can not be turned and the Ride Height Control Valve will maintain vehicle ride height.

Position “stop”

When the lever is in the central position and pushed in the air bags will be isolated from the Ride Height Control Valve and no air will be allowed to flow into or out of the air bags.

Position “raising”

When the lever is in the “stop” position it may be turned in a counterclockwise direction approximately 45°. Connections 21, 22 are linked with connection 1 and the air bags are inflated. On release the lever automatically returns to the “stop” position.

Position “lowering”

When the lever is in the “stop” position it may be turned in a clockwise direction approximately 45°. Connections 21 and 22 are linked with connection 3 (which is the exhaust port) and the air bags are deflated. On release the lever automatically returns to the “stop” position.

Installation Instructions

1. Mount the Colas Valve using at least two of the four mounting holes provided on the valve.
 - a. The valve should be mounted in a location where it is protected from direct road spray.
 - b. The handle of the valve should not protrude past the side of the vehicle.

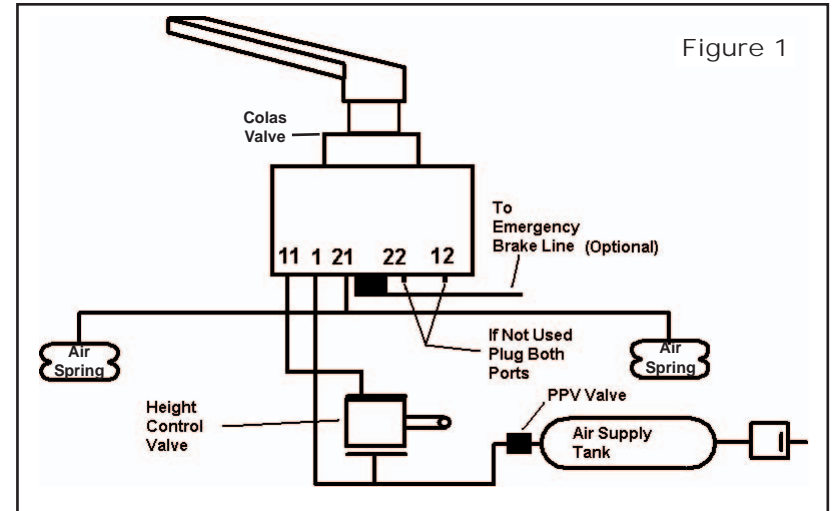

Figure 1

Note: There are two sets of supply and delivery ports on the Colas Valve. Both may be used at the same time, but if only one set is used the other must be plugged or the valve will not operate properly. Port 11 (from HCV) corresponds with delivery port 21 and Supply port 12 (from HCV) corresponds with delivery port 22 on the Colas Valve.

2. Connect the delivery port(s) of the Height Control Valve to the supply port(s) 11 and/or 12 on the Colas Valve. (See Figure 1)
3. Connect the Corresponding delivery port(s) to the air springs bags. (See Figure 1)
4. Connect port 1 on the Colas Valve directly to the air supply down stream of the PPV. (See Figure 1)
5. Connect the middle port on the Colas Valve to the emergency break line. This feature is optional and is used for automatically resetting the valve back to the “drive” position with release of the emergency brake. (See Figure 1)